

INTRODUCTION TO MICROWAVE ENGINEERING

ECE 524E – Microwave Engineering
Tuesday, 17 February 2026

ECE 524E - SYLLABUS

Course Content:

Introduction: Components of RF and microwave design, Behaviour of passive components, Propagation of guided waves. Micro-stripline circuits; Evaluation of attenuation constant for the rectangular waveguide. Waveguides and Components: Review of electromagnetic (EM) spectrum. Rectangular waveguides, Circular Waveguides, Microwave cavities. Microwave antennas: electromagnetic horns; reflector antennas; micro-strip antennas; phased arrays. Micro Strip Antenna. Directional couplers. Circulators, isolators. Wave guide couplings, bends and twists, Transitions, hybrid couplers, Matched load, Attenuators and phase shifters, E-plane, H-plane and Hybrid Tees, Hybrid ring. Waveguide discontinuities: Windows, Irises and Tuning screws, Detectors, wave meters. Strip Lines: Microstrip lines. Parallel strip lines. Coplanar strip lines. Shielded strip lines. Microwave Active circuits: Microwave transistors and tunnel diodes. Microwave FETs. Transferred electron devices: Avalanche transit time devices. Microwave linear beam tubes. Microwave crossed-field tubes. Microwave Communication Systems: Effect of Biological Exposure to microwave radiation. Microwave tubes: Klystron, Reflex Klystron, Magnetron, TWT, BWO: Their schematic, Principle of operation, performance characteristics and application. Microwave semiconductor devices: PIN diode, Tunnel diode, LSA diode, varactor diode, Gunn Devices, IMPATT and TRAPATT, their Principal of operation, characteristics and applications. Microwave Relays: Line-of-site path characteristics, FM radio stations and repeaters, FM microwave systems, analogue FM/AM, analogue versus digital switching arrangements.

ECE 524E - CURRICULUM(1)

ECE 524E MICROWAVE ENGINEERING

Prerequisites

ECE 312 - Electromagnetics I, ECE 322 - Electromagnetics II, MAT 202 - Engineering Mathematics II, ECE 514: Transmission Lines

Purpose

1. To introduce students to microwave components and circuits in terms of scattering parameters, electrical characteristics of waveguides through electromagnetic field analysis, and basics of microwave amplifiers.
2. Students are expected to analyse microwave network through application to impedance matching and tuning, design of microwave resonators, passive components, filters, and microwave antennas.

LEARNING OUTCOMES (1)

Upon completion of this course, a student should be able to:

- i. discuss the operation of components and devices used in RF & Microwave systems;
- ii. describe the principles of design and operation of devices for generation & processing of RF signals at different power levels;
- iii. discuss the applications of RF & microwave systems in communication, control and instrumentation;
- iv. discuss recent developments in broadband communications for voice, data and video communication requirements and their relationship with microwaves;

LEARNING OUTCOMES (2)

Upon completion of this course, a student should be able to:

V. design microwave antenna;

VI. explain the basic structures of RF / microwave transmission lines (microstrip, strip);

VII. identify TEM, TE, and TM waves;

VIII. explain operation of rectangular waveguide;

IX. describe the lumped element circuit model for a transmission line;

X. design impedance matching networks for microwave circuits.

ECE 524E-COURSE DESCRIPTION (1)

- 1. Introduction:** Components of RF and microwave design, Behaviour of passive components, Propagation of guided waves. Micro-stripline circuits; Evaluation of attenuation constant for the rectangular waveguide.

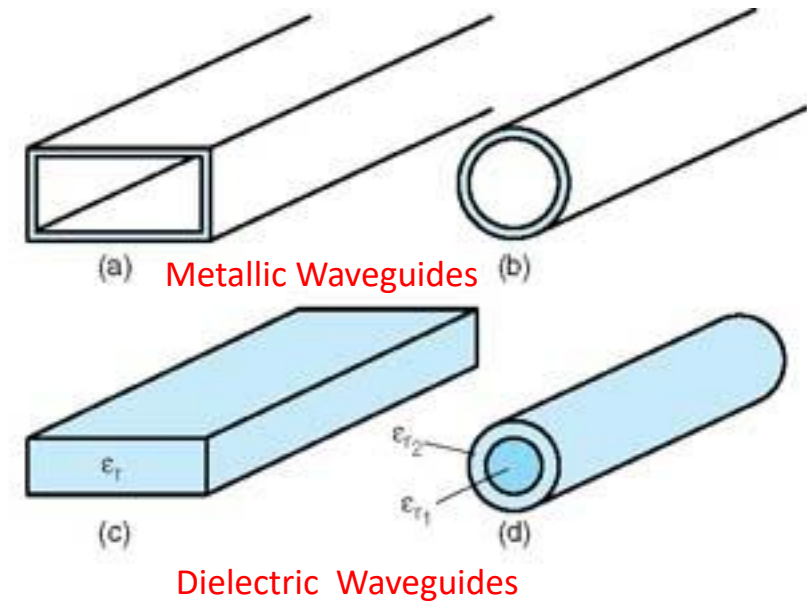
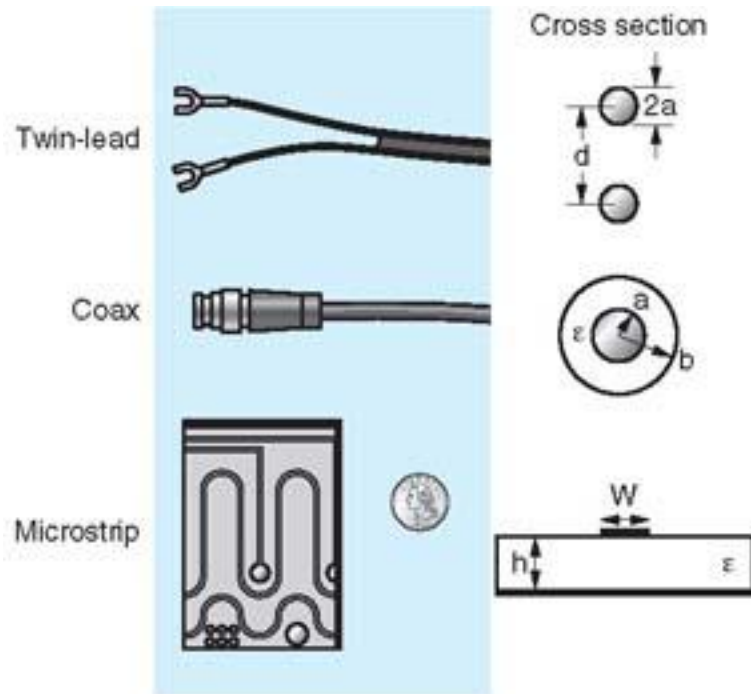

ECE 524E--COURSE DESCRIPTION (2)

2. Waveguides and Components: Review of electromagnetic (EM) spectrum. Rectangular waveguides, Circular Waveguides, Microwave cavities.

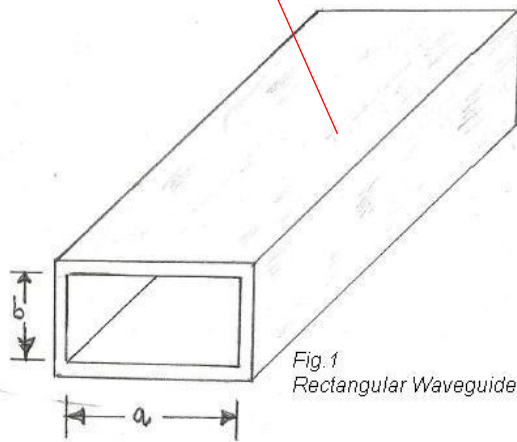

(a) Rectangular Waveguide

A hollow metallic tube with a rectangular cross section. The conducting walls of the waveguide confine the electromagnetic fields and thereby guide the electromagnetic wave.

In the inner air-filled volume of the tube, electromagnetic waves can propagate above mode-specific cut-off frequencies

circular waveguide

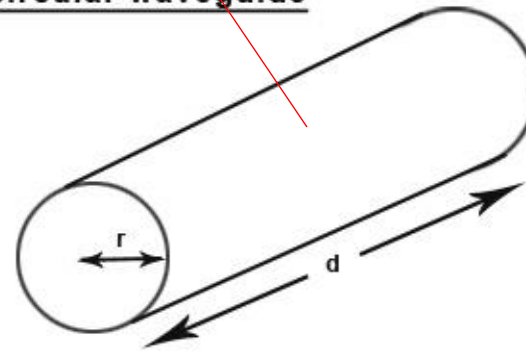

(b) Circular Waveguide:

A hollow metallic cylinder with an inner radius R .

In the inner air-filled volume of the cylinder electromagnetic waves can propagate above mode-specific cut-off frequencies

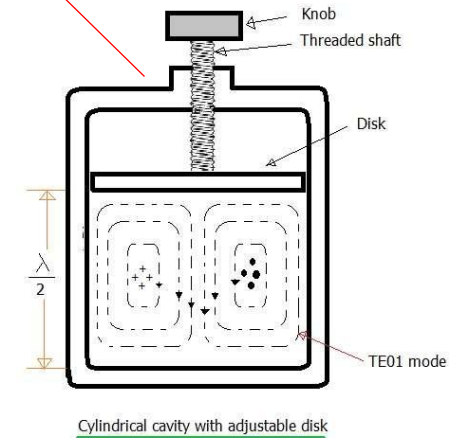

(c) A microwave cavity

A special type of resonator, consisting of a closed (or largely closed) metal structure that confines electromagnetic fields in the microwave region of the spectrum.

ECE 524E- -COURSE DESCRIPTION (3)

3. Microwave antennas: electromagnetic horns; reflector antennas; micro-strip antennas; phased arrays.

Directional couplers. Circulators, isolators. Wave guide couplings, bends and twists, Transitions, hybrid couplers, Matched load, Attenuators and phase shifters, E-plane, H-plane and Hybrid Tees, Hybrid ring.

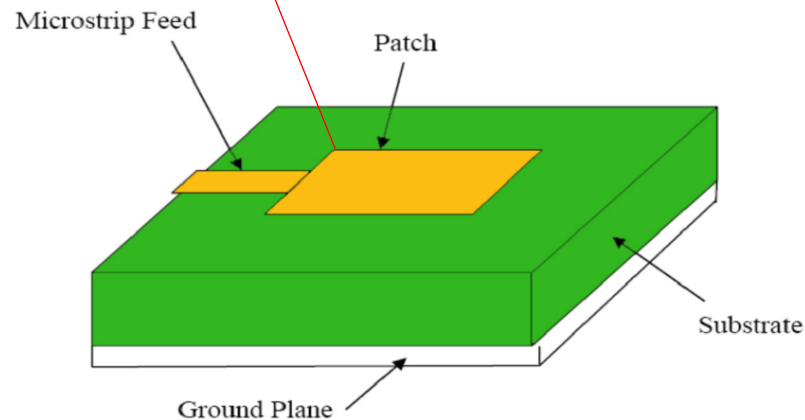

(a) Microstrip antenna

An antenna fabricated using microstrip techniques on a printed circuit board (PCB).

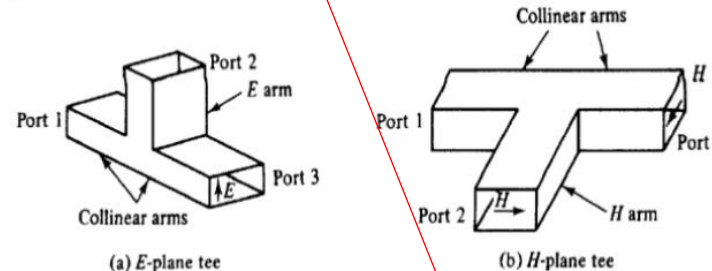

(b) Waveguide Hybrid Tee

A 3-port device that can be used to either divide or combine power in a waveguide system.

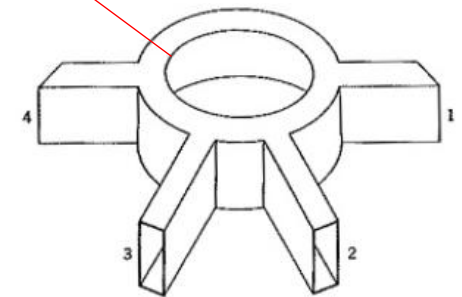

(c) Hybrid ring

A type of coupler used in RF and microwave systems. In its simplest form, it is a 3 dB coupler

ECE 524E- -COURSE DESCRIPTION (4)

4. Waveguide discontinuities: Windows, Irises and Tuning screws, Detectors, wave meters.

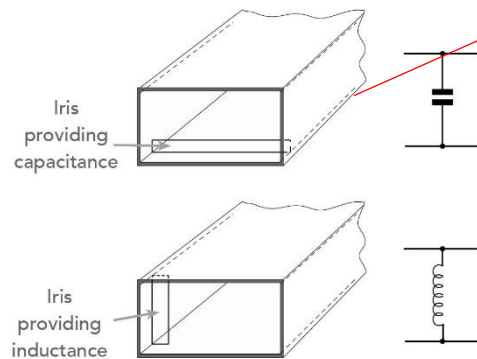

(a) Waveguide iris

Used to place a shunt capacitance or inductance across the waveguide.

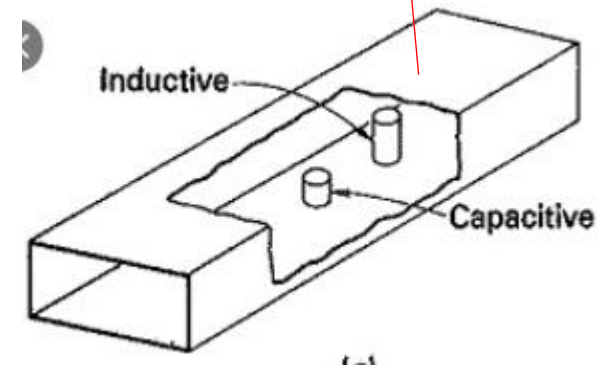

Tuning screws

Screws inserted into resonant cavities which can be adjusted externally to the waveguide.

ECE 524E--COURSE DESCRIPTION (4)

5. Strip Lines: Microstrip lines. Parallel strip lines. Coplanar strip lines. Shielded strip lines.

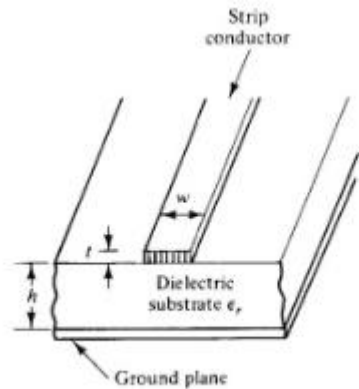

(a) Stripline

A form of printed circuit transmission line where the signal trace is sandwiched between upper and lower ground planes,

ECE 524E--COURSE DESCRIPTION (6)

6. Microwave Active circuits: Microwave transistors and tunnel diodes; Microwave FETs.

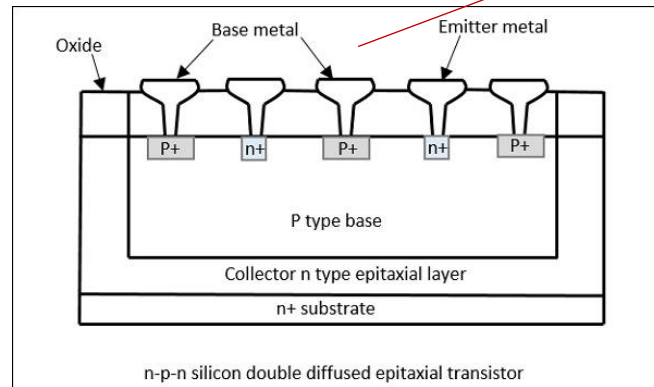

(a) Microwave Transistors

Silicon n-p-n transistors that can provide adequate powers at microwave frequencies have been developed. They are with typically up to 5 watts at a frequency of 3GHz with a gain of 5dB.

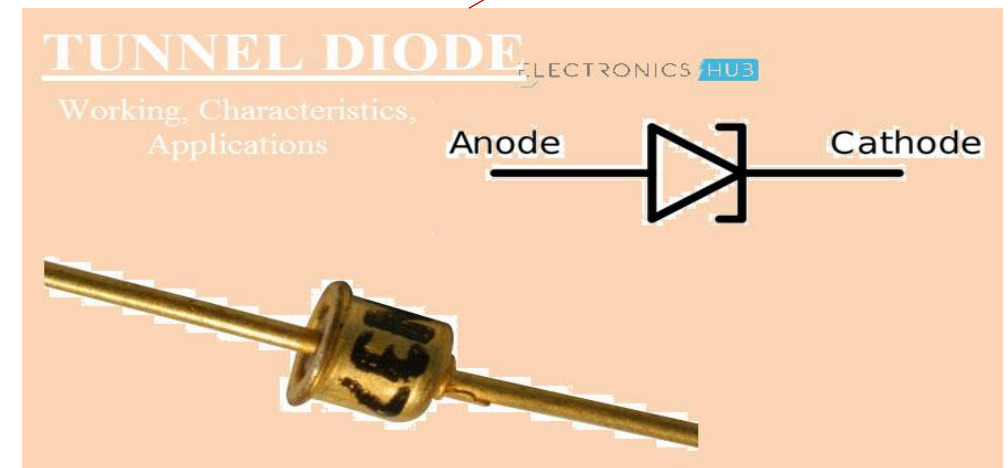

(b) Tunnel diode

A semiconductor diode that exhibits negative resistance, meaning the current decreases with an increase in voltage. Tunnel diode can be used as a switch, amplifier, and oscillator.

ECE 524E--COURSE DESCRIPTION (7)

7. Transferred electron devices: Avalanche transit time devices.
Microwave linear beam tubes. Microwave crossed-field tubes.
Microwave Communication Systems. Effect of Biological Exposure to microwave radiation.

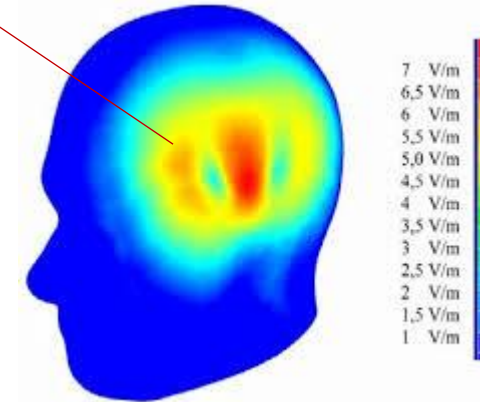
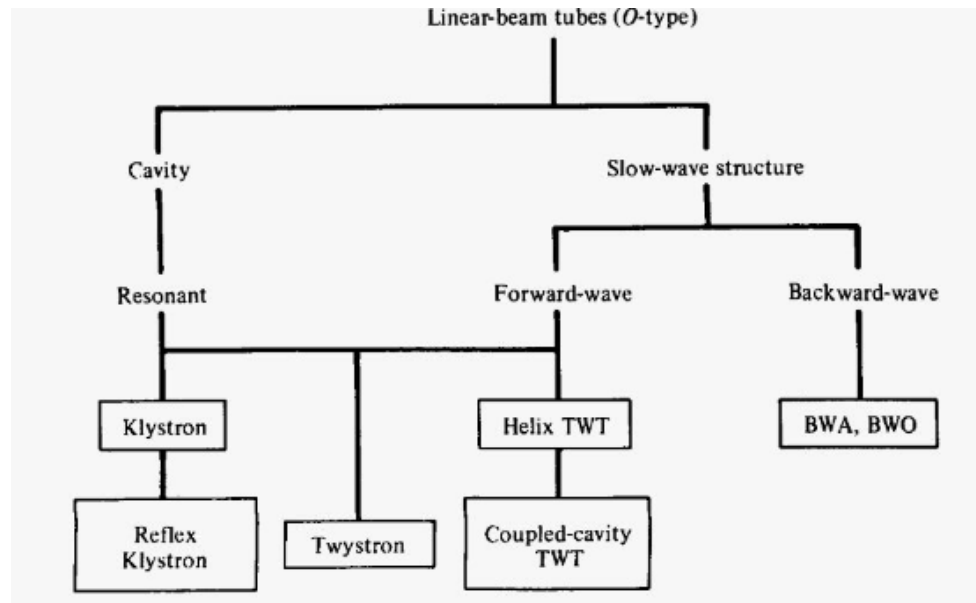

Biological Exposure to Microwave Radiation

Microwave radiation can heat body tissue the same way it heats food. Exposure to high levels of microwaves can cause a painful burn.

Two areas of the body, the eyes and the testes, are particularly vulnerable to RF heating because there is relatively little blood flow in them to carry away excess heat.

ECE 524E--COURSE DESCRIPTION (8)

8. Microwave tubes: Klystron, Reflex Klystron, Magnetron, TWT, BWO. Their schematic, Principle of operation, performance characteristics and application.

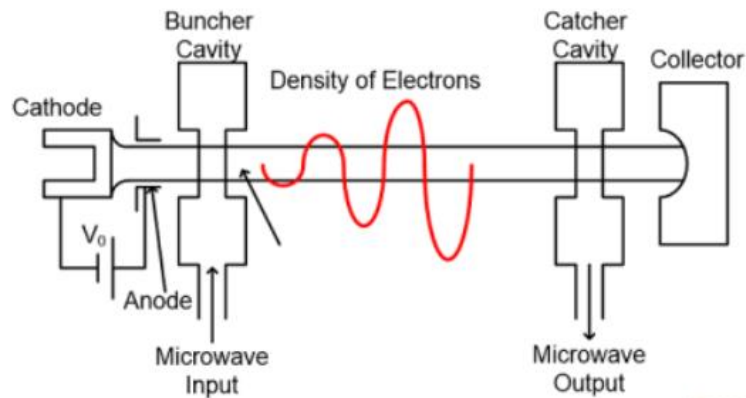

(a) Klystron

A Klystron (also known as a Klystron Tube or Klystron Amplifier) is a vacuum tube that is used to oscillate and amplify microwave frequency signals.

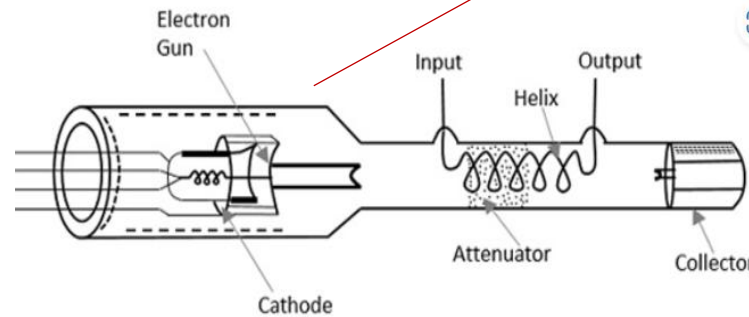

(b) Travelling Wave Tube

Broadband microwave amplifiers which have no cavity resonators like Klystrons. Amplification is done through the prolonged interaction between an electron beam and Radio Frequency

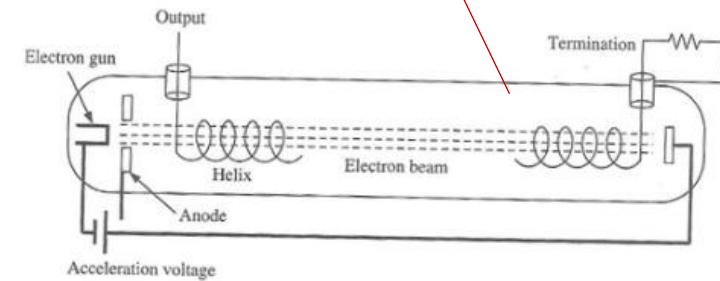

(c) Backward Oscillator

RF wave travelling backwards in opposite direction to the electron beam in helix structure. Frequency of oscillation depends on voltage between cathode and helix.

ECE 524E--COURSE DESCRIPTION (9-1)

9. Microwave semiconductor devices: PIN diode, Tunnel diode, LSA diode, varactor diode, Gunn Devices, IMPATT and TRAPATT, their Principal of operation, characteristics and applications.

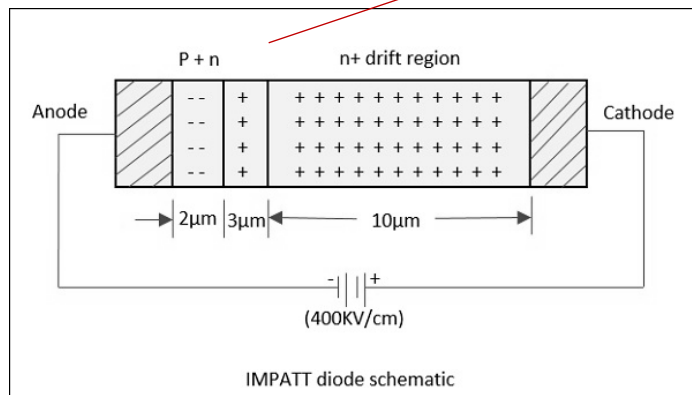

IMPATT diode (IMPact ionization Avalanche Transit-Time diode)

A form of high-power semiconductor diode used in high-frequency microwave electronics devices. They have negative resistance and are used as oscillators and amplifiers at microwave frequencies.

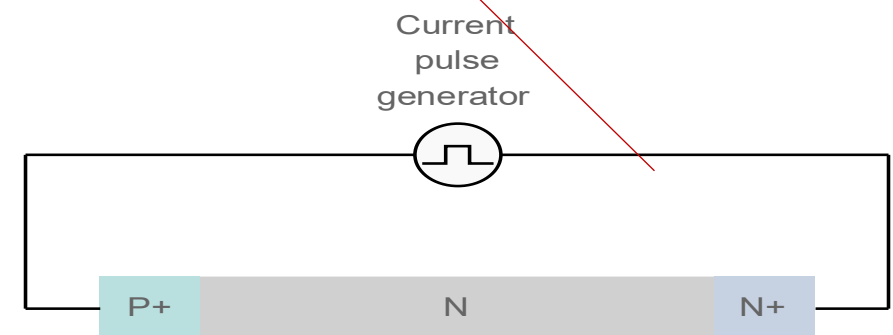

TRAPATT or TRApped, Plasma Avalanche Triggered Transit diode

The TRAPATT diode is based around the initial concept of the IMPATT but it has been enhanced by increasing the doping level between the junction and the anode

ECE 524E--COURSE DESCRIPTION (9-2)

9. Microwave semiconductor devices: PIN diode, Tunnel diode, LSA diode, varactor diode, Gunn Devices, IMPATT and TRAPATT, their Principal of operation, characteristics and applications.

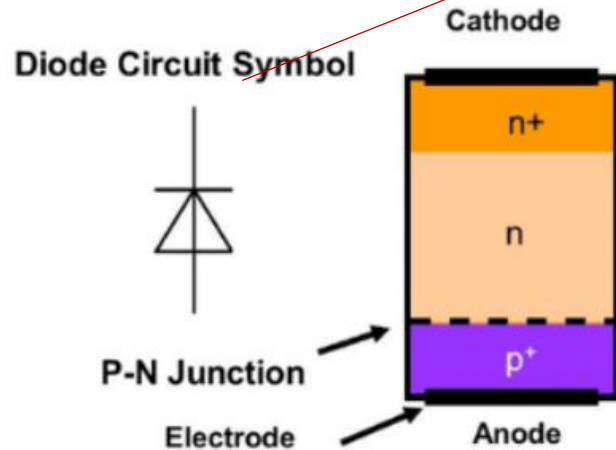

PIN Diode

A special type of diode that contains an undoped intrinsic semiconductor between the p-type semiconductor and n-type semiconductor regions.

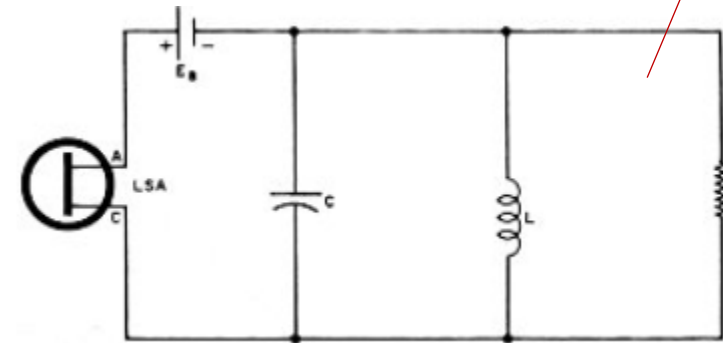

LSA (Limited Space-charge Accumulation) diode

A transferred-electron diode similar to the Gunn diode except that it is intended to operate at frequencies that are determined by the microwave cavity in which the diode is mounted and that are several times higher than the transit-time frequency so that the formation of charge packets (or domains) is limited.

ECE 524E--COURSE DESCRIPTION (9-3)

9. Microwave semiconductor devices: PIN diode, Tunnel diode, LSA diode, Varactor diode, Gunn Devices, IMPATT and TRAPATT, their Principal of operation, characteristics and applications.

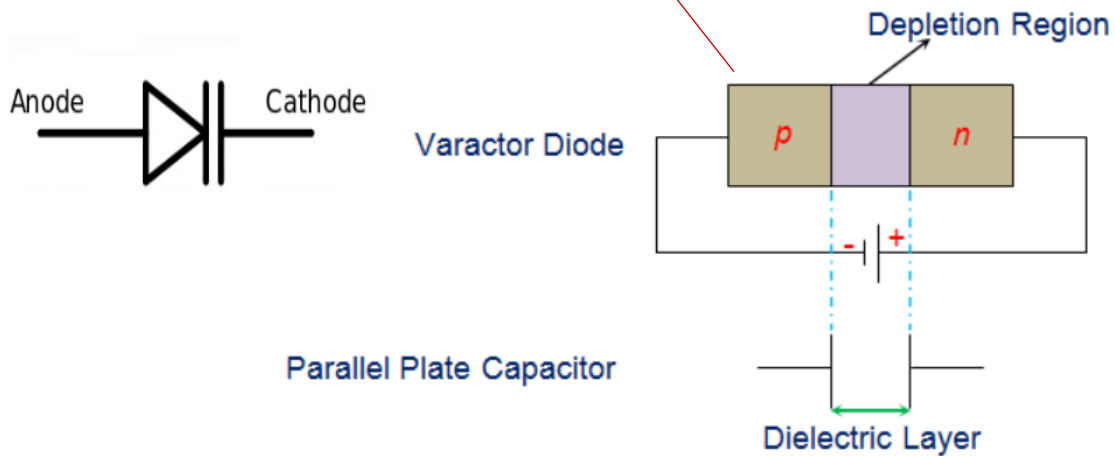

Varactor Diode

A type of diode whose internal capacitance varies with respect to the reverse voltage. It always works in reverse bias ...

1. **Varactor diodes** are compact in size, economical, reliable and less noisy compared to other diodes.
2. Hence, they are used in the following applications:
 - a) **Tuning circuits** to replace the old-style variable capacitor tuning of FM radio
 - b) Tank circuits of receiver or transmitter for auto-tuning as in case of TV
 - c) Signal modulation and demodulation.
 - d) Microwave frequency multipliers as a component of LC resonant circuit
 - e) Very low noise microwave parametric amplifiers

ECE 524E--COURSE DESCRIPTION (9-4)

9. Microwave semiconductor devices: PIN diode, Tunnel diode, LSA diode, varactor diode, Gunn Devices, IMPATT and TRAPATT, their Principal of operation, characteristics and applications.

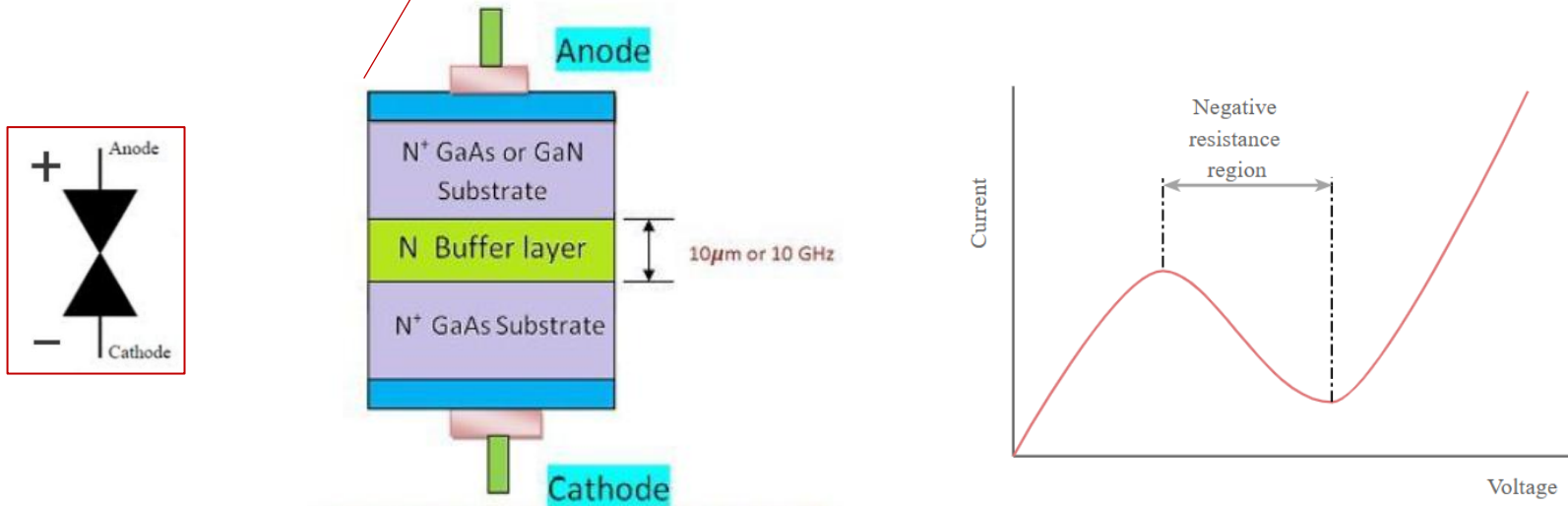

Gunn Diode

A passive semiconductor device with two terminals, which composes of only an n-doped semiconductor material, unlike other diodes which consist of a p-n junction. Gunn diodes can be made from the materials which consist of multiple, initially-empty, closely-spaced energy valleys in their conduction band like Gallium Arsenide (GaAs), Indium Phosphide (InP), Gallium Nitride (GaN), Cadmium Telluride (CdTe), Cadmium Sulfide (CdS), Indium Arsenide (InAs), Indium Antimonide (InSb) and Zinc Selenide (ZnSe).

ECE 524E-COURSE DESCRIPTION (10)

- **10. Microwave Relays:** Line-of-site path characteristics, Microwave radio stations and repeaters.

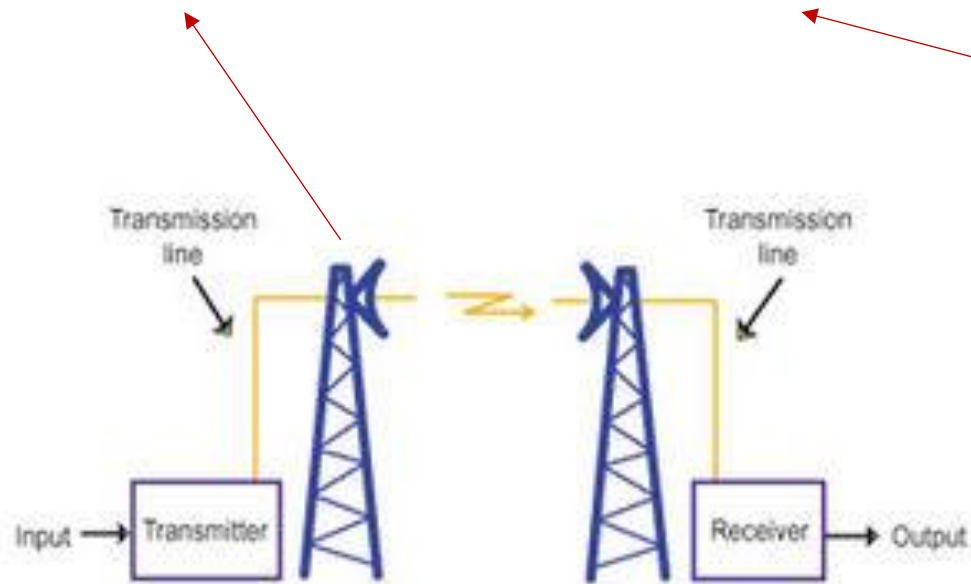

Microwave radio relay

A technology widely used for transmitting signals, such as long-distance telephone and video between two terrestrial points on a narrow beam of microwaves

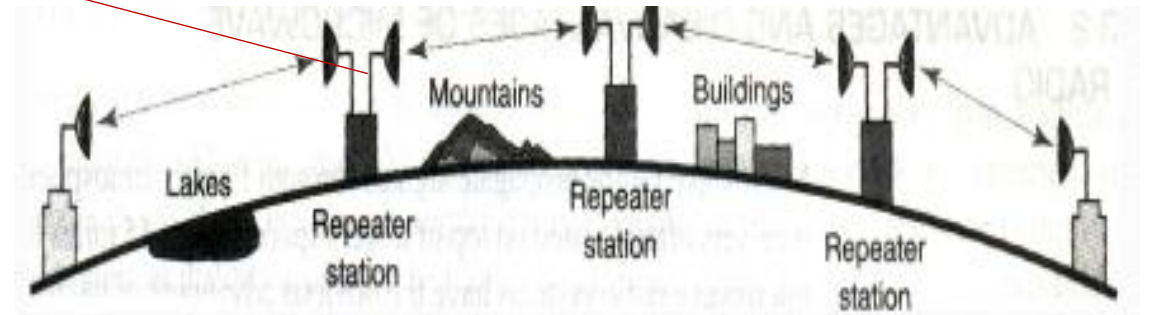

Microwave repeater Stations

Microwave RF repeaters are designed to transfer signals from one radio link to another without loss of quality, data, or traffic, while compensating for multipath and fading loss

WHAT ARE MICROWAVES

1. Microwaves are a form of electromagnetic radiation with frequencies between 300 MHz (1 m) and 300 GHz (1 mm)
2. The prefix **micro- in microwave** is not meant to suggest a wavelength in the micrometer range. Rather, it indicates that microwaves are "small" (having shorter wavelengths), compared to the radio waves used prior to microwave technology.
3. The boundaries between far infrared, terahertz radiation, microwaves, and UHF waves are fairly arbitrary and vary in different fields of study.

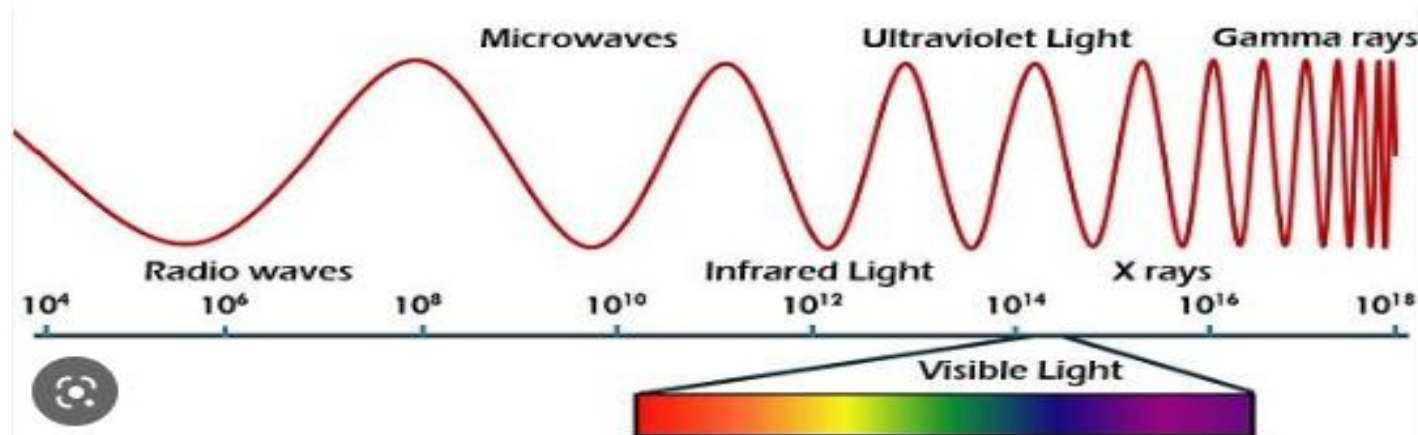

STANDARD RADAR FREQUENCY LETTER-BAND NOMENCLATURE (IEEE STANDARD 521-2002)

BAND DESIGNATOR	FREQUENCY (GHZ)	WAVELENGTH IN FREE SPACE (CENTIMETERS)
HF	0.003 to 0.030	10000 to 1000
VHF	0.030 to 0.300	1000 to 100
UHF	0.300 to 1	100 to 30.0
L band	1 to 2	30.0 to 15.0
S band	2 to 4	15 to 7.5
C band	4 to 8	7.5 to 3.8
X band	8 to 12	3.8 to 2.5
Ku band	12 to 18	2.5 to 1.7
K band	18 to 27	1.7 to 1.1
Ka band	27 to 40	1.1 to 0.75
V band	40 to 75	0.75 to 0.40
W band	75 to 110	0.40 to 0.27
mm	110 to 300	0.27 to 0.10

 **Microwaves**