

MICROWAVE SOLID-STATE DEVICES

ECE 524E – MICROWAVE ENGINEERING

Monday, April 13, 2026

WHERE ARE WE IN THE SYLLABUS?

Course Content:

Introduction: Components of RF and microwave design, Behaviour of passive components, Propagation of guided waves. Micro-stripline circuits; Evaluation of attenuation constant for the rectangular waveguide. Waveguides and Components: Review of electromagnetic (EM) spectrum. Rectangular waveguides, Circular Waveguides, Microwave cavities. Microwave antennas: electromagnetic horns; reflector antennas; micro-strip antennas; phased arrays. Micro Strip Antenna. Directional couplers. Circulators, isolators. Wave guide couplings, bends and twists, Transitions, hybrid couplers, Matched load, Attenuators and phase shifters, E-plane, H-plane and Hybrid Tees, Hybrid ring. Waveguide discontinuities: Windows, Irises and Tuning screws, Detectors, wave meters. Strip Lines: Microstrip lines. Parallel strip lines. Coplanar strip lines. Shielded strip lines. Microwave Active circuits: Microwave transistors and tunnel diodes. Microwave FETs. Transferred electron devices: Avalanche transit time devices. Microwave linear beam tubes. Microwave crossed-field tubes. Microwave Communication Systems. Effect of Biological Exposure to microwave radiation. Microwave tubes: Klystron, Reflex Klystron, Magnetron, TWT, BWO: Their schematic, Principle of operation, performance characteristics and application. Microwave semiconductor devices: PIN diode, Tunnel diode, LSA diode, varactor diode, Gunn Devices, IMPATT and TRAPATT, their Principal of operation, characteristics and applications. Microwave Relays: Line-of-site path characteristics, FM radio stations and repeaters, FM microwave systems, analogue FM/AM, analogue versus digital switching arrangements.

TYPES OF MICROWAVE TRANSISTORS

1. MESFETs (Metal-Semiconductor FETs)
2. HEMTs (High Electron Mobility Transistors)
3. MOSFETs
4. BJTs
5. HBTs (Heterojunction Bipolar Transistors)

APPLICATIONS OF MICROWAVE TRANSISTORS

1. Microwave transistors are used in
 - a) Low Noise Amplifiers (LNA)
 - b) Power Amplifiers
 - c) Mixers
 - d) Frequency converters and multipliers
 - e) Attenuators
 - f) Phase shifters

2. Microwave transistors can be classified into 2 categories:
 - a) low-noise transistors
 - b) power transistors

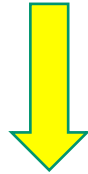
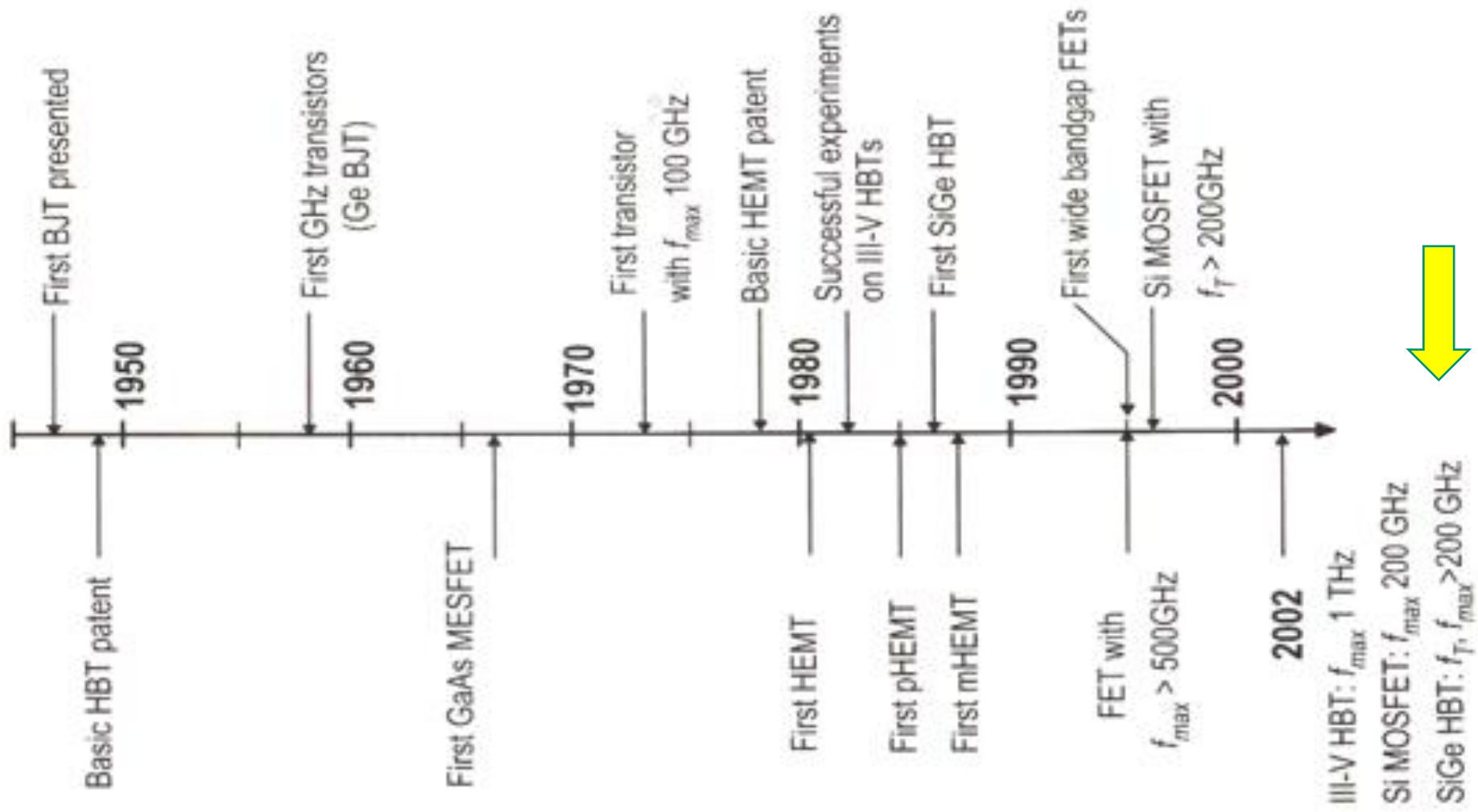

MICROWAVE TRANSISTORS (2)

- 1. Microwave transistors** are designed to minimize capacitances and transit time.
- 2. NPN bipolar and N channel FETs** preferred because free electrons move faster than holes.
- 3. Gallium Arsenide** preferred at greater than 5 GHz because it has greater electron mobility compared to silicon

PARASITIC CAPACITANCES

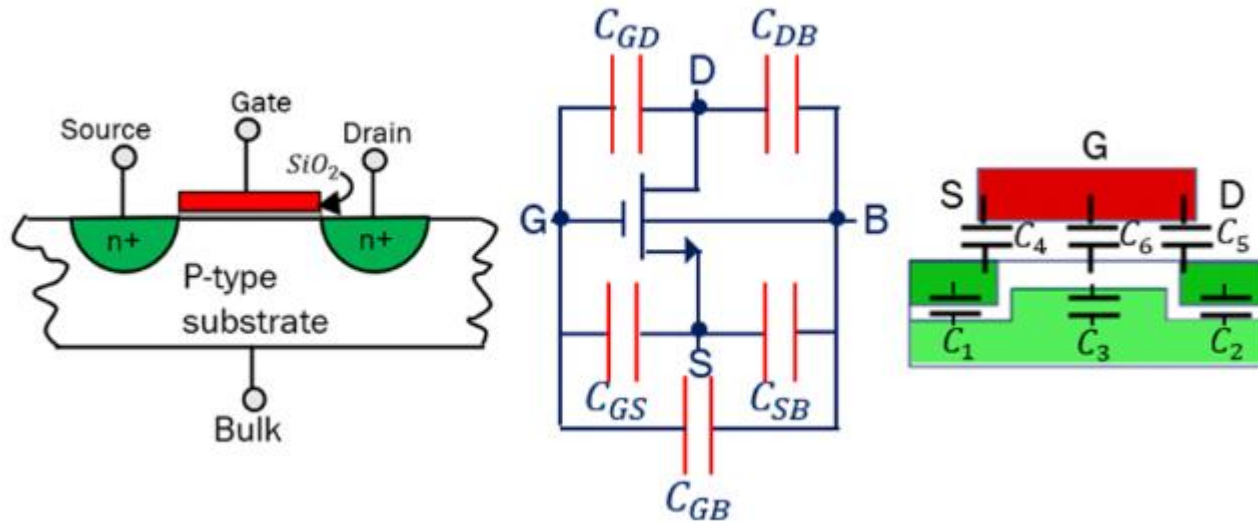

1. **Parasitic capacitances** are formed due to the separation of mobile charges at various regions within the structure.
2. The Capacitances are the unwanted component in the circuit which are often neglected at low-frequency but have adverse effects at microwave frequencies.

TRANSIT TIME & DISPERSION

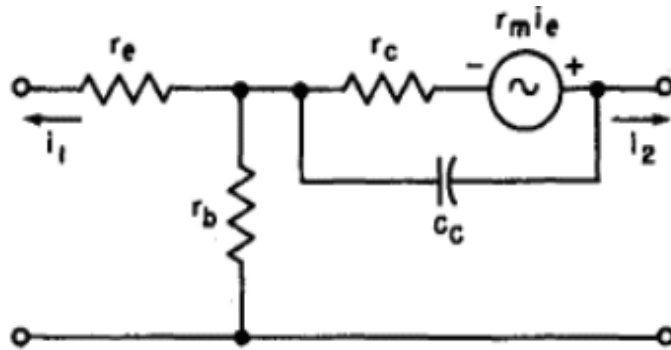

The movement of holes or electrons from the emitter through the base layer to the collector requires a short but finite time.

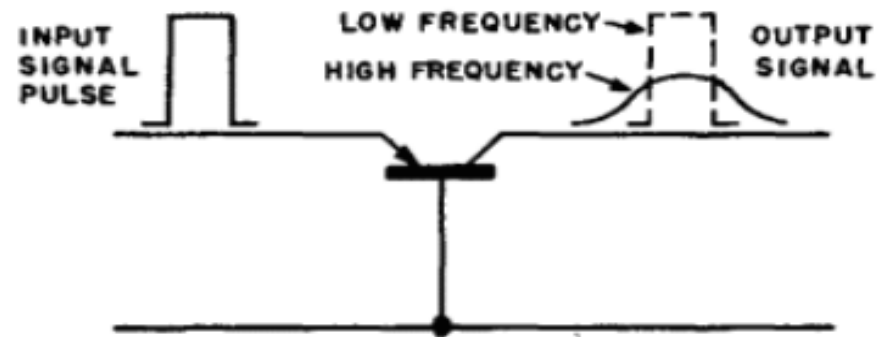

At the higher frequencies, differences in the transit time causes a smearing or partial cancellation between the carriers resulting in pulse dispersion as shown.

ADVANTAGES OF MICROWAVE TRANSISTORS

The advantages of transistors over other microwave devices are:

1. Long Shelf and working lives,
2. Small size
3. Low electrode voltages
4. **Low power dissipation**
5. **Good efficiencies, of the order of 40 percent.**
6. **Excellent noise figures and bandwidths**

MICROWAVE TRANSISTOR CONSTRUCTION

4. Connectors

Connector contacts are attached to the different regions.

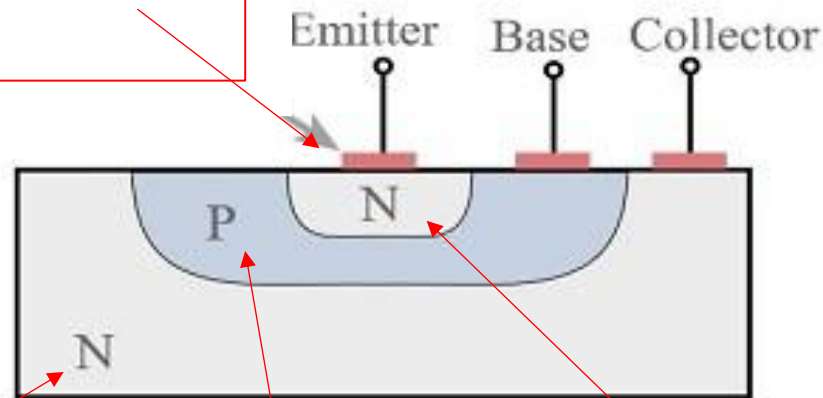

1. Collector

Low resistivity Silicon substrate acts as the collector.

2. B-Region

Above the epitaxial layer a p region is diffused

3. E-Region

n⁺ layer is diffused over the p region to form the emitter.

WHAT IS GUNN EFFECT?

- **Gunn effect** is the production of rapid fluctuations of current when the voltage applied to a semiconductor device exceeds a critical value with the result that microwave power is generated.

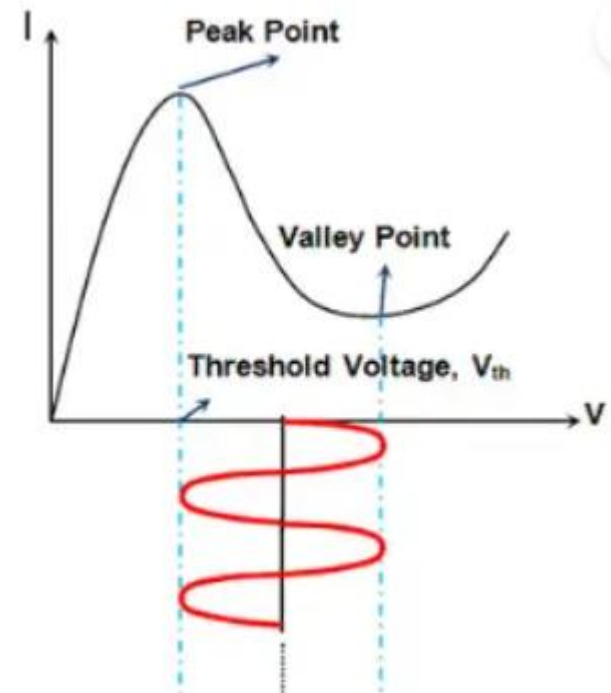

GUNN DIODE

- A Gunn diode is a passive semiconductor device with two terminals, which composes of only an n-doped semiconductor material, unlike other diodes which consist of a p-n junction.

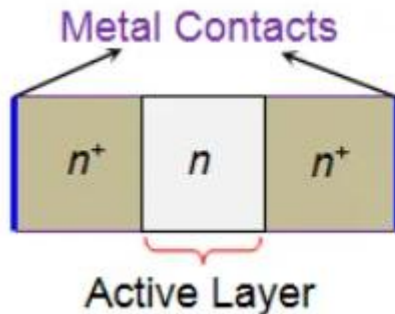

(a) Gunn Diode Construction

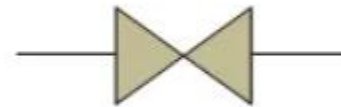

(a) Gunn Diode Symbol

V-I CHARACTERISTICS OF A GUNN DIODE

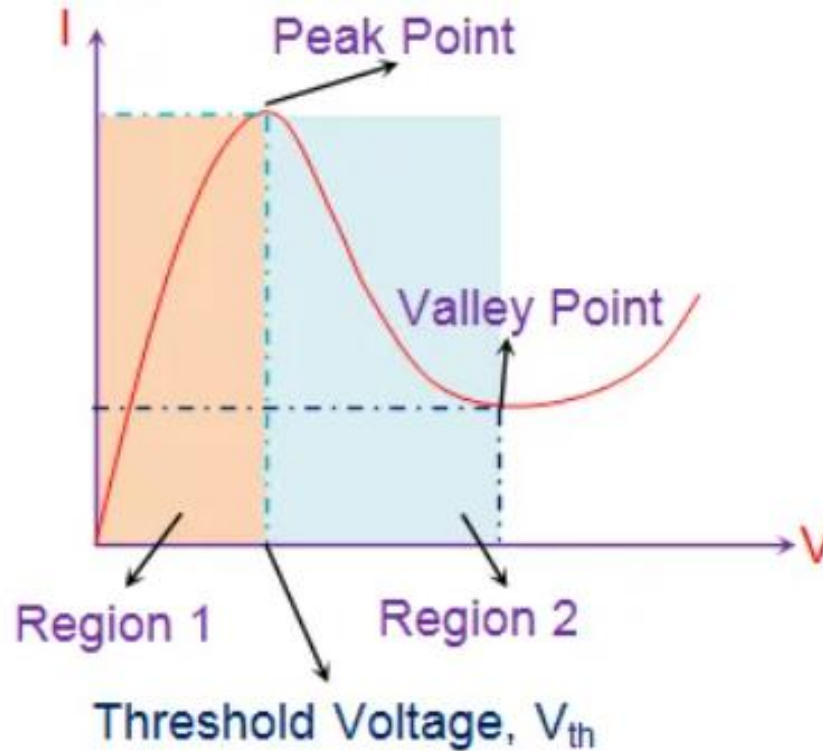

1. **Gunn diode exhibit negative resistance region** (region spanning from Peak point to Valley Point) in the V-I characteristic curve.
2. This effect is called transferred electron effect.

DISCOVERY OF GUNN EFFECT

1. The transferred electron effect is also called Gunn effect and is named after John Battiscombe Gunn (J. B. Gunn) after his discovery in 1963.
2. Gunn showed that one could generate microwaves by applying a steady voltage across a chip of n-type GaAs semiconductor.

ADVANTAGES GUNN DIODE

Advantage of Gunn diodes are:

1. They are the cheapest source of microwaves compared to other options such as klystron tubes.
2. They are compact in size
3. They operate over a large bandwidth and possess high frequency stability.

DISADVANTAGES GUNN DIODE

The disadvantages of Gunn diodes are:

1. They have a high turn-on voltage
2. They are less efficient below 10 GHz
3. They exhibit poor temperature stability.

PRINCIPLE OF GUNN OSCILLATOR

1. The negative differential resistance of the diode cancels the positive resistance of the load circuit, thus creating a circuit with **zero differential resistance**, which produces spontaneous oscillations..
2. The amplitude of the resultant oscillations is limited by the limits of the negative resistance region.

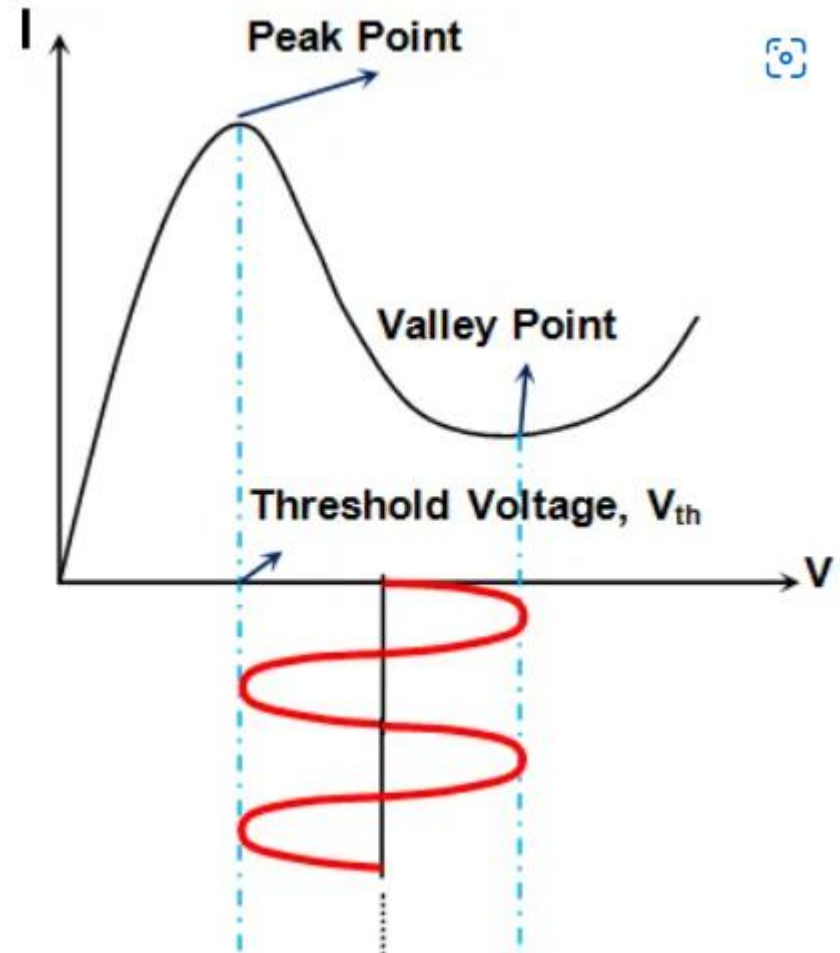

COMMERCIAL GUNN DIODE OSCILLATOR

- The diode is mounted inside the cavity (metal box), which functions as a resonator to determine the frequency.
- The negative resistance of the diode excites microwave oscillations in the cavity which radiate out the rectangular hole into a waveguide.
- The frequency can be adjusted by changing the size of the cavity using the slot head screw.



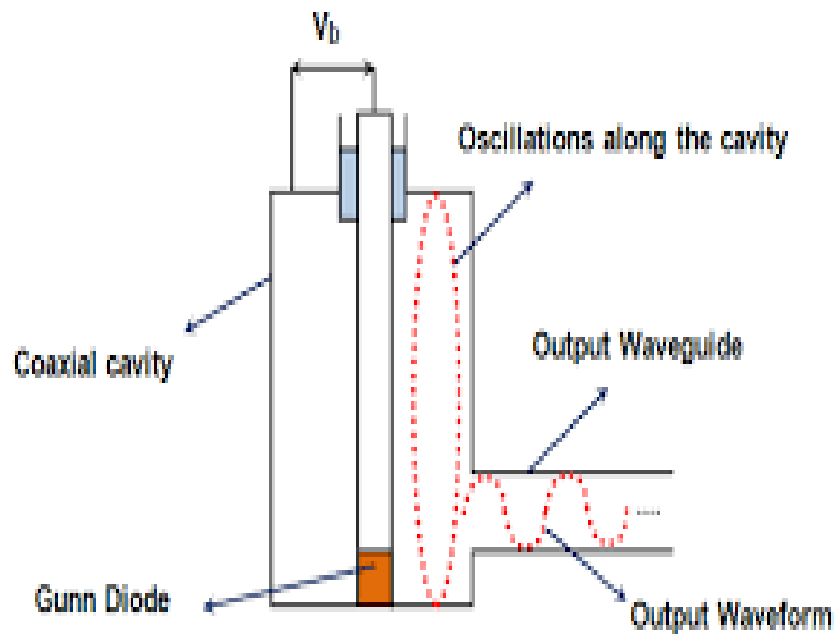

Figure 2 Coaxial Cavity Based Gunn Diode Oscillator Design



APPLICATIONS OF GUNN DIODE

The applications of a Gunn Diode include:

1. In electronic oscillators to generate microwave frequencies.
2. In parametric amplifiers as pump sources.
3. In police radars.
4. In radar speed guns.
5. As microwave relay data link transmitters.
6. In Continuous Wave Doppler Radars.