

MICROWAVE OVEN

ECE 524E-MICROWAVE SYSTEMS

Tuesday, 18 March 2025

IONIZING Vs NON-IONIZING RADIATION

Radiation with enough energy to remove tightly bound electrons from the orbit of an atom, causing the atom to become charged or ionized.

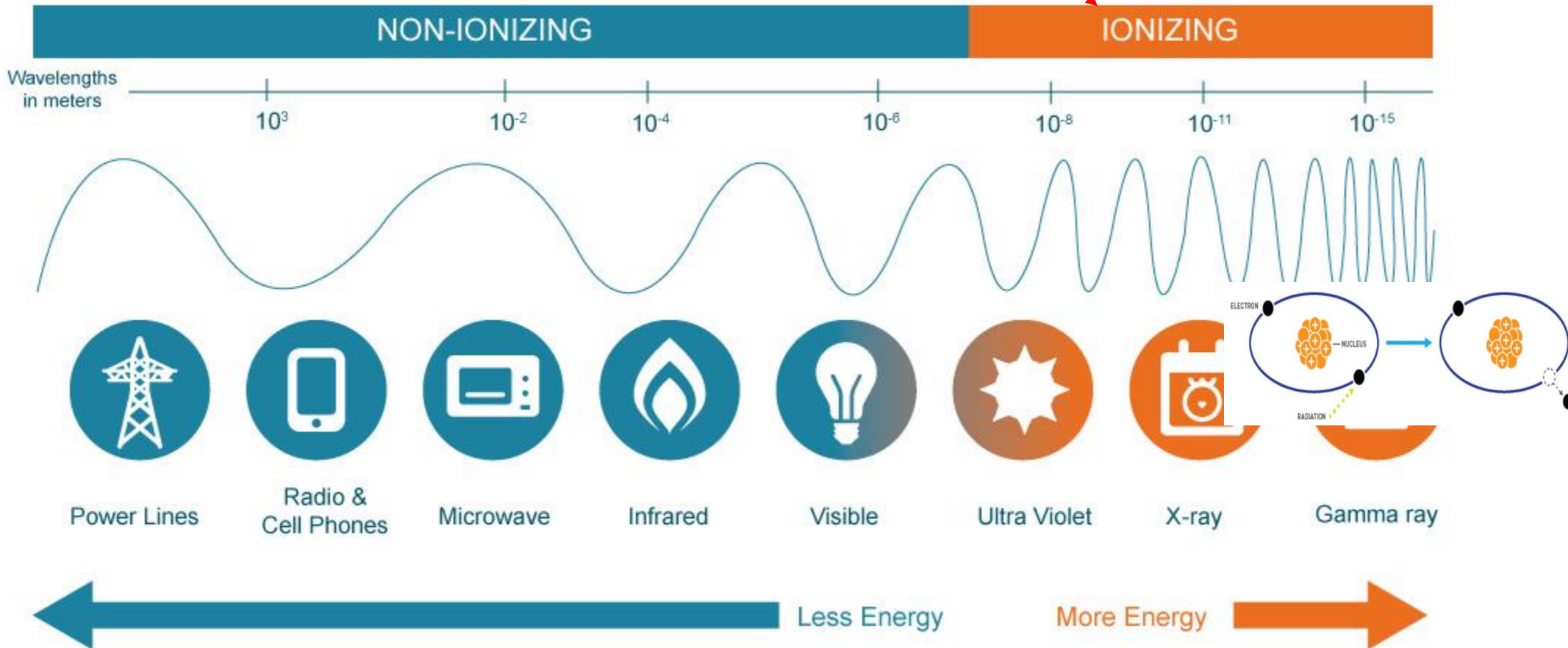

BRIEF HISTORY OF MICROWAVE OVEN

1. In 1945, Percy Spencer, working for **Raytheon** to develop magnetrons for active radar signals, noticed a chocolate bar in pocket melted while standing in front of an operating magnetron.
2. He then placed popcorn in front of the magnetron and it quickly popped all over the room.
3. In 1947, Raytheon made the first microwave oven – Radarange (6 ft tall, 3000 W power \$3,000) but did not sell well.
4. In 1965, a tabletop version was developed and sold for \$495.
5. Today a domestic microwave oven sells for about KSh. 15,000 (\$115)

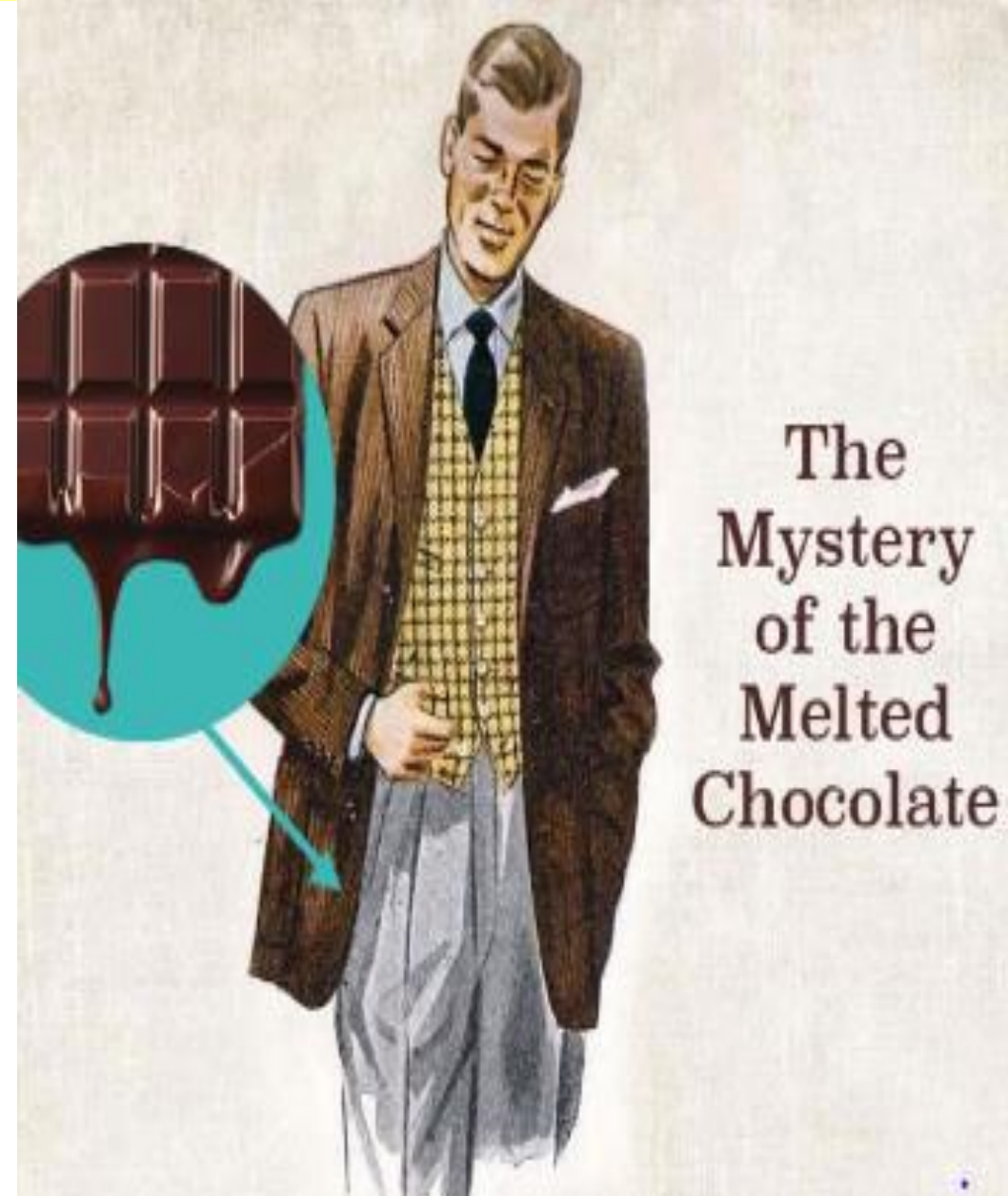

SOME BACKGROUND CHEMISTRY

1. **Water molecule same number of electrons and protons, so it is neutral.**
2. **The oxygen atom and hydrogen atoms share electrons in covalent bonds, but the sharing is not equal.**
3. **In the covalent bond between oxygen and hydrogen, the oxygen atom attracts electrons a bit more strongly than the hydrogen atoms.**
4. **The unequal sharing of electrons gives the water molecule a slight negative charge near its oxygen atom and a slight positive charge near its hydrogen atoms.**
5. **When a neutral molecule has a positive area at one end and a negative area at the other, it is a polar molecule.**

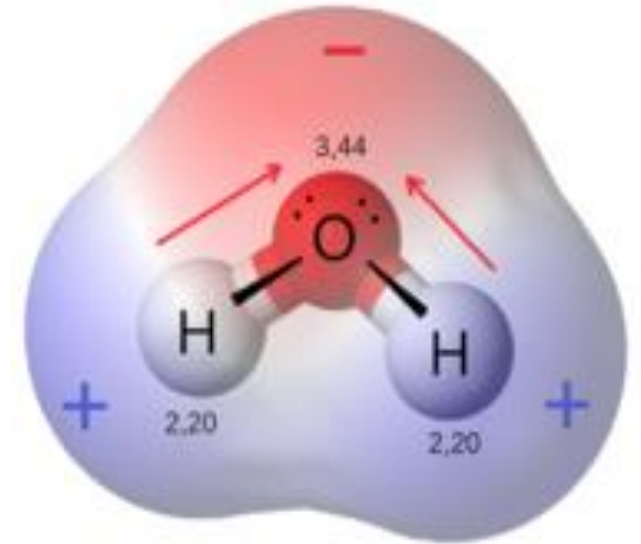

HOW A MICROWAVE OVEN WORKS(1)

1. Microwave ovens selectively make liquid (water) hot.
2. Most food, even "dry" foods, have water in them.
3. Water (H_2O) is a polar molecule with 2 hydrogen atoms being more positive than the single oxygen atom.
4. In liquid water, the molecules are in constant motion and are normally randomly oriented.
5. Glass, paper, ceramic, or plastic containers are used in microwave cooking because the microwaves pass through them.
6. **Metals reflect microwaves**
7. **It is unsafe to have metal pans/aluminium foil in oven, may damage oven**

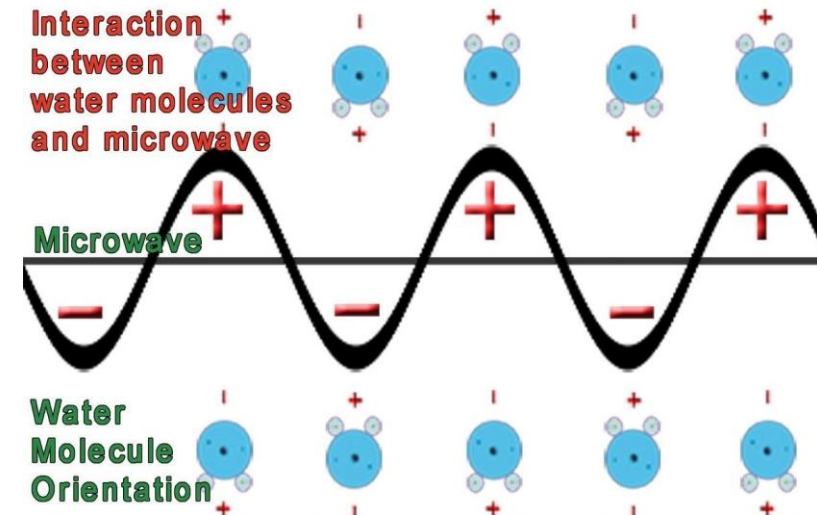
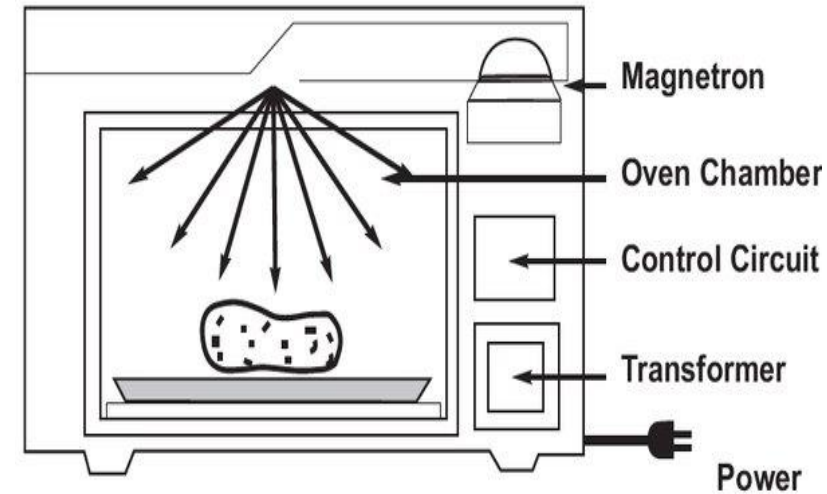

HOW A MICROWAVE OVEN WORKS(2)

1. The water molecules follow the oscillation of the electric field.
2. They collide more frequently with the molecules (water and other) around them.
3. As molecules move faster and faster, and the temperature increases (heating)..

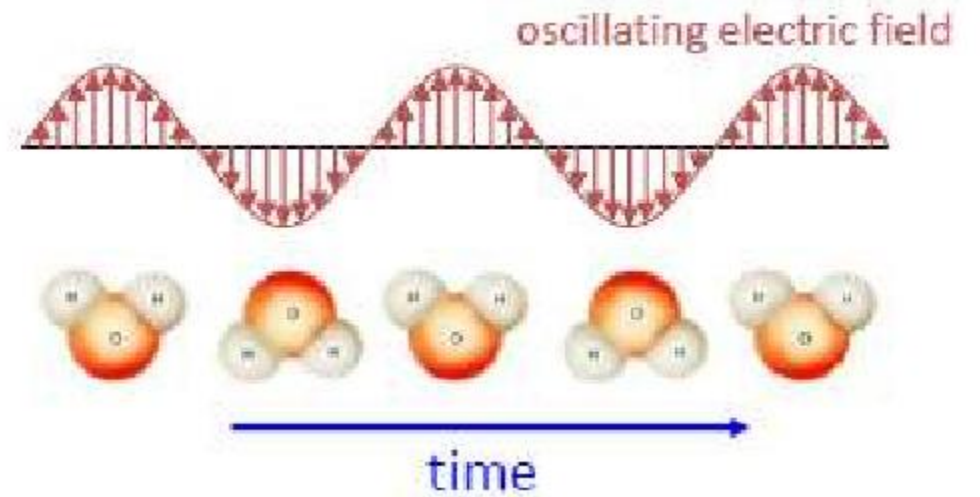

MICROWAVE OVEN FREQUENCY BAND

- 1. Over time, microwaves were standardized to operate at 2.45 GHz.**
- 2. In 1985, ITU established the ISM band (2.40 -2.45 GHz) so other unlicensed wireless devices could co-exist with microwave ovens**

HOW A MICROWAVE OVEN WORKS(3)

- Inside a microwave oven, the electromagnetic waves also form standing waves from reflections at the walls.
- Without a turntable, the food will not be cooked uniformly due to nodes and antinodes in the oven

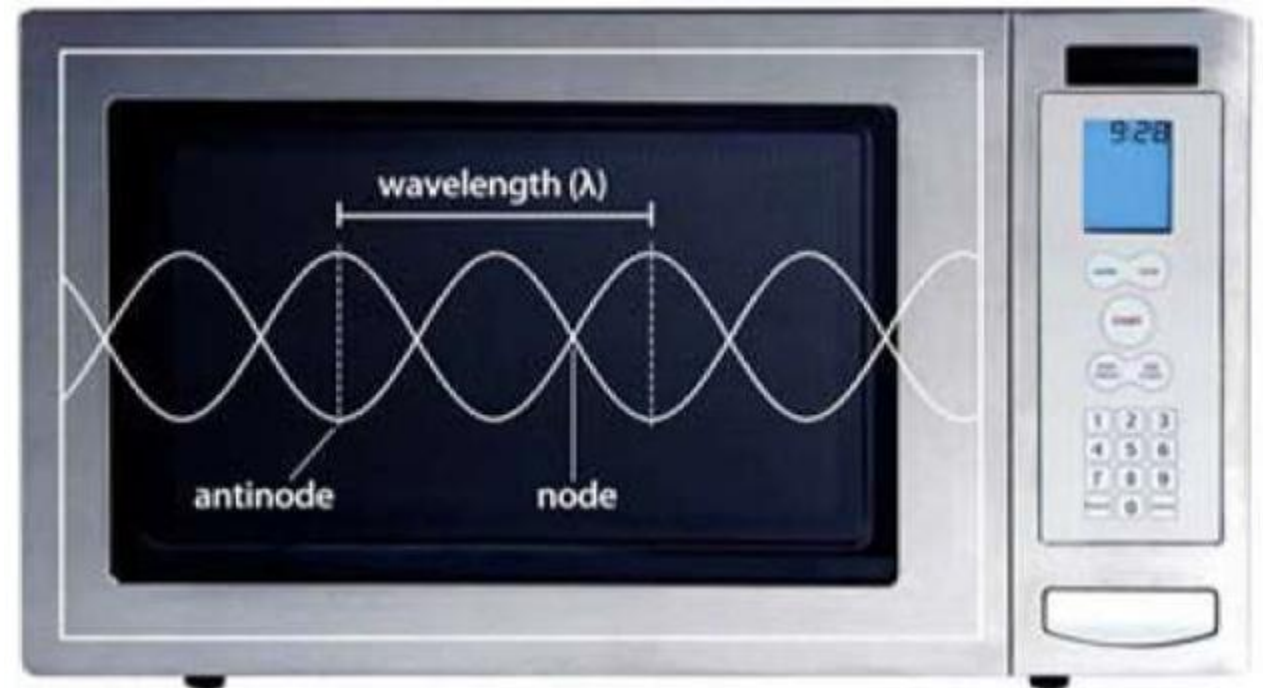
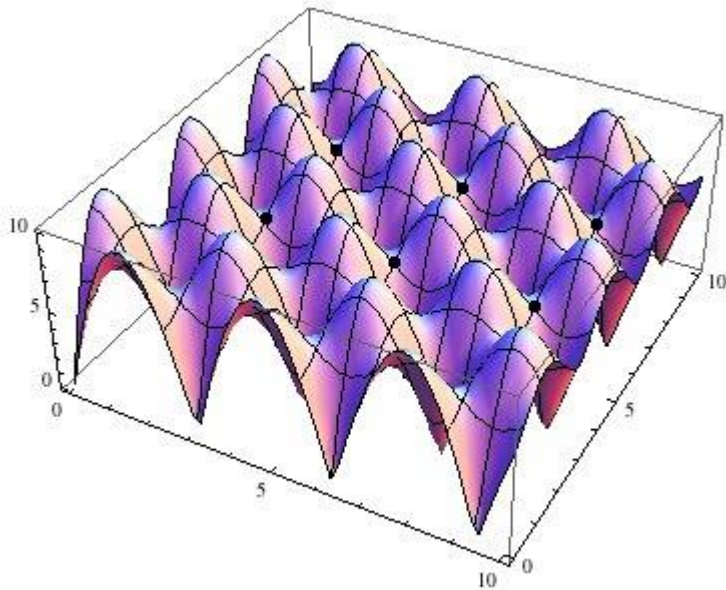

THE MICROWAVE OVEN MAGNETRON(1)

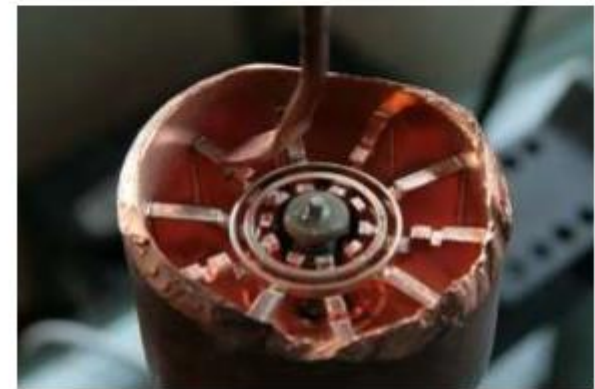
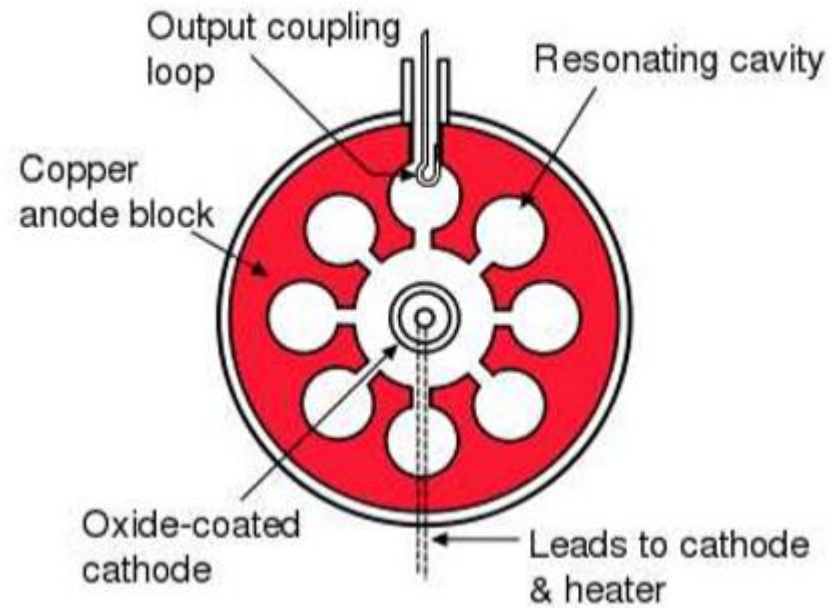

THE MICROWAVE OVEN MAGNETRON (2)

Cathode emits electrons which travel outward

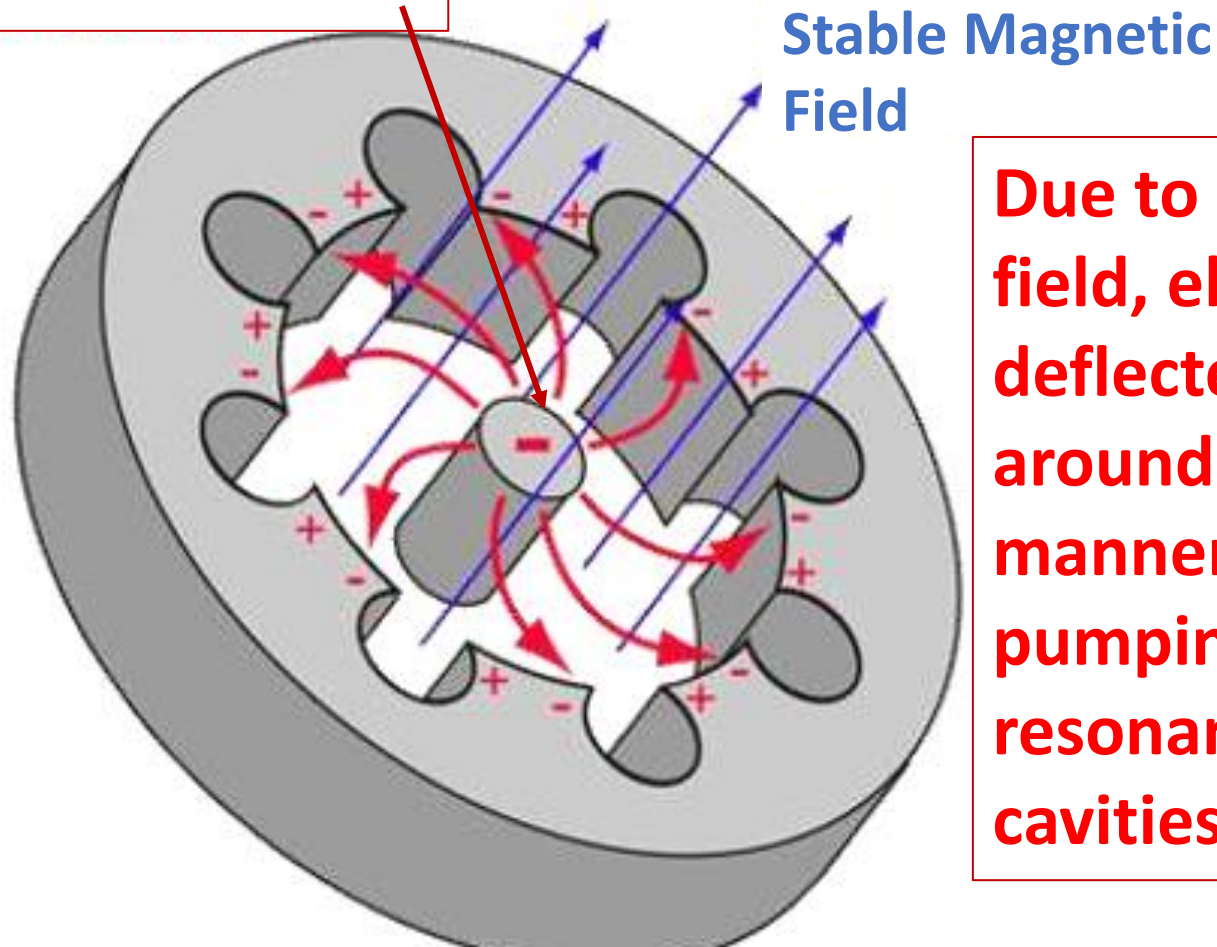

Due to the magnetic field, electrons get deflected and move around in a circular manner thereby pumping into the resonant frequency cavities.

COMPONENTS OF A MICROWAVE OVEN /1

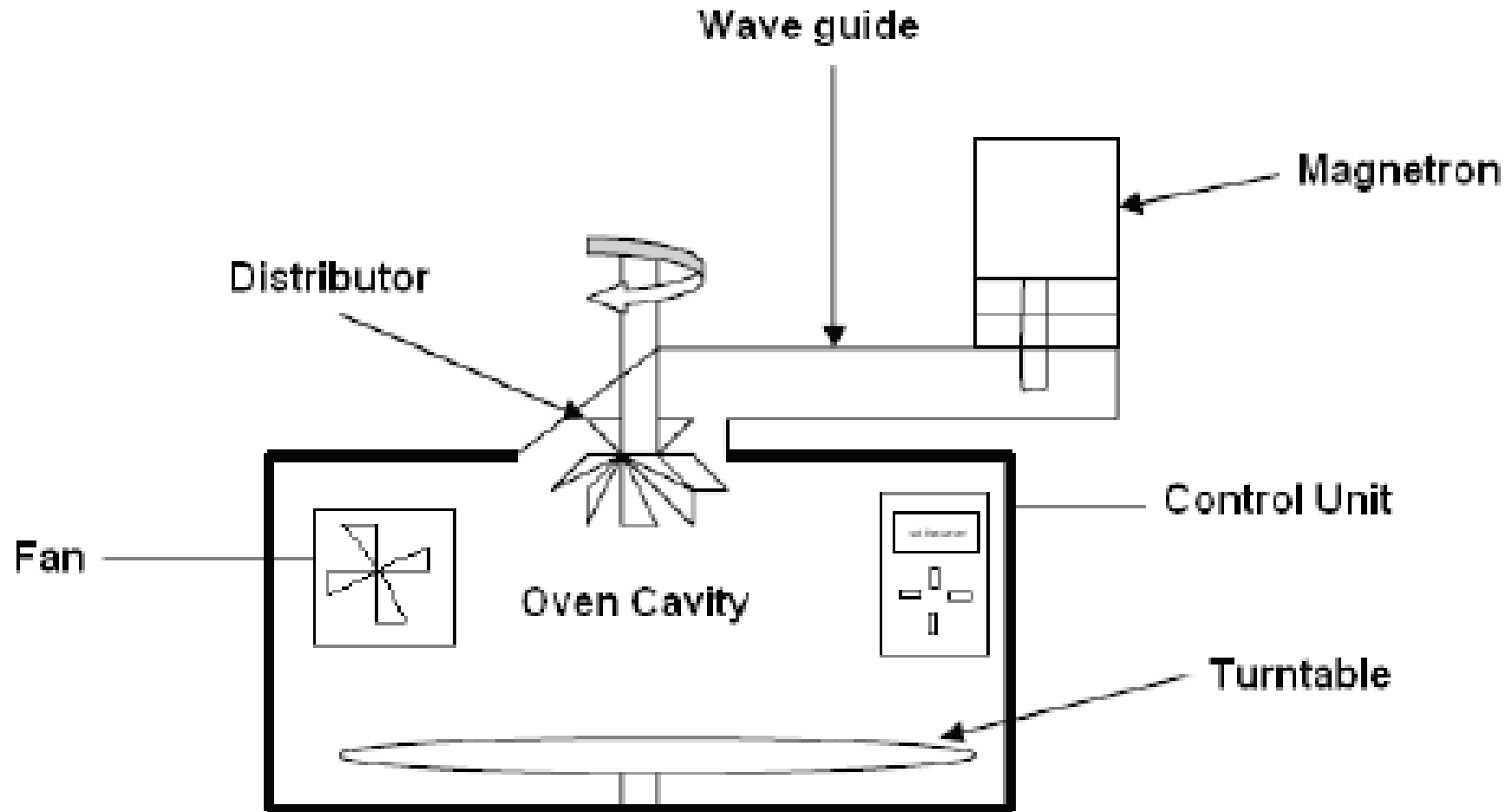

COMPONENTS OF A MICROWAVE OVEN /2

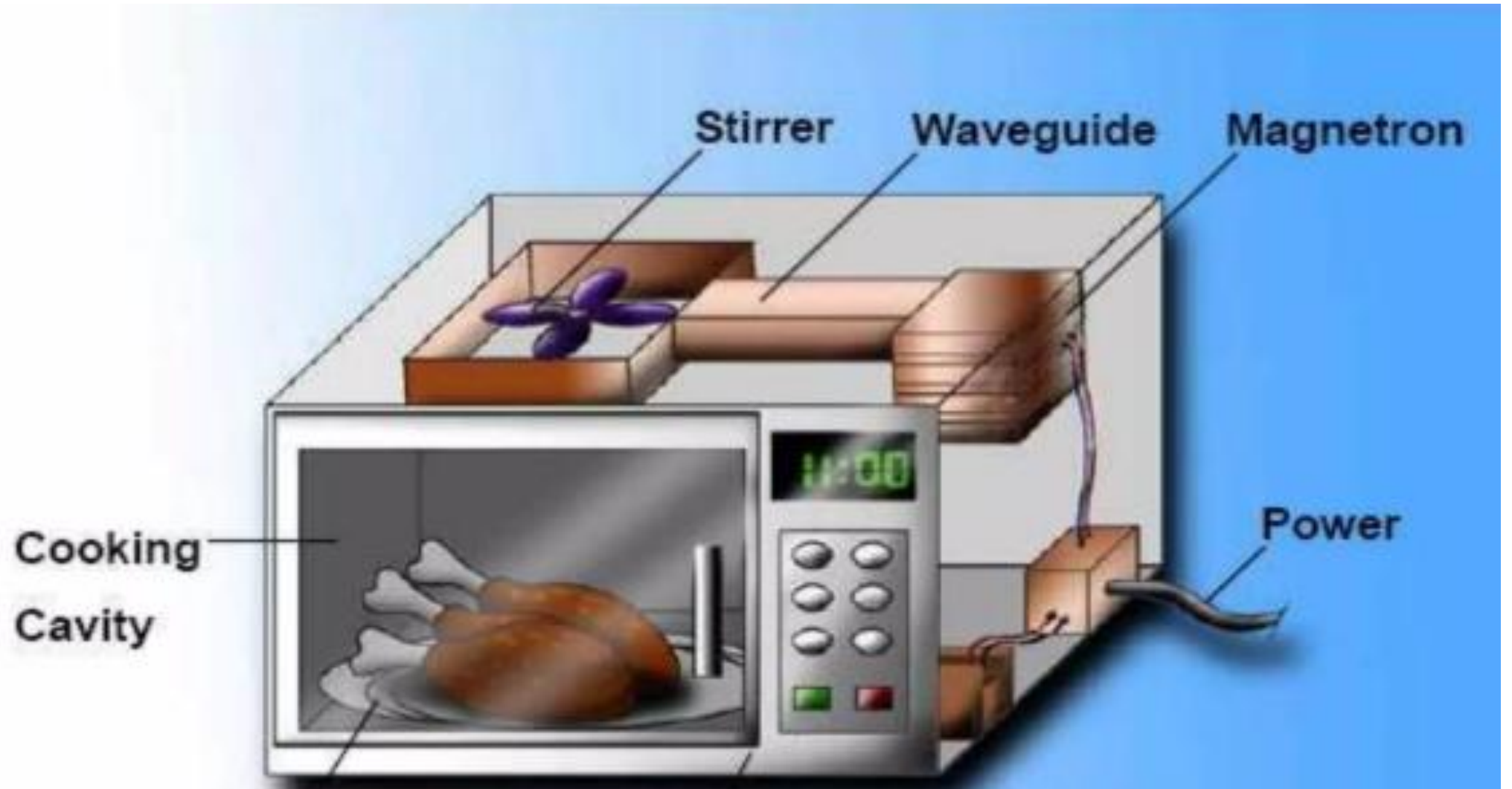

ELECTRIC BLOCK DIAGRAM OF MICROWAVE OVEN

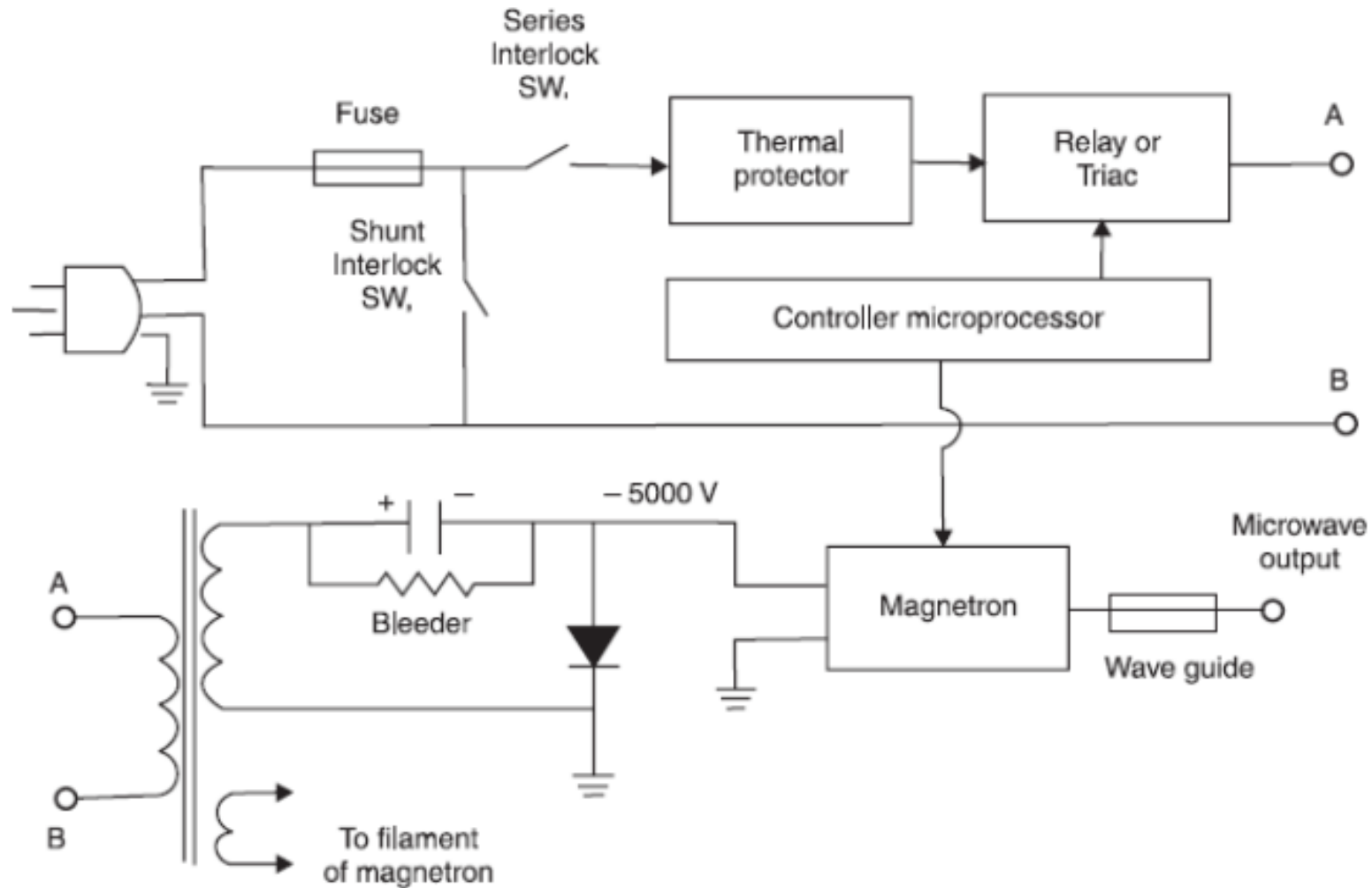

ADVANTAGES/DISADVANTAGES OF MICROWAVE OVENS

ADVANTAGES	DISADVANTAGES
<ol style="list-style-type: none">1. Cooking time is short2. Destruction of nutrients is less3. No physical change of foods4. Melting process is easy5. Sterilization effect exists6. There is no flame	<ol style="list-style-type: none">1. Constraint with metal container2. Heat force control is difficult3. Water evaporation4. Closed container is dangerous because it could burst5. Surface toasting is impossible

OTHER CONCERNS

1. If food is enclosed in a metal container, then sparks are generated and no foods heat up.
2. If food is different in ingredients heating rates could be different. For instance, sections with more fat will be heat up faster.
3. Radiation effect to human body which is only the thermal.