

# MICROWAVE AMPLIFIERS & GENERATORS

**ECE 524E – MICROWAVE ENGINEERING**

**Tuesday, 18 March 2025**

# ELECTRONICS BEFORE TRANSISTORS

1. **Triode valve** is a vacuum tube with three electrodes:
  - a) Cathode (heated filament)
  - b) Control grid
  - c) Anode (plate)
2. The grid voltage controls the flow of electrons between the cathode and anode, allowing for signal amplification.

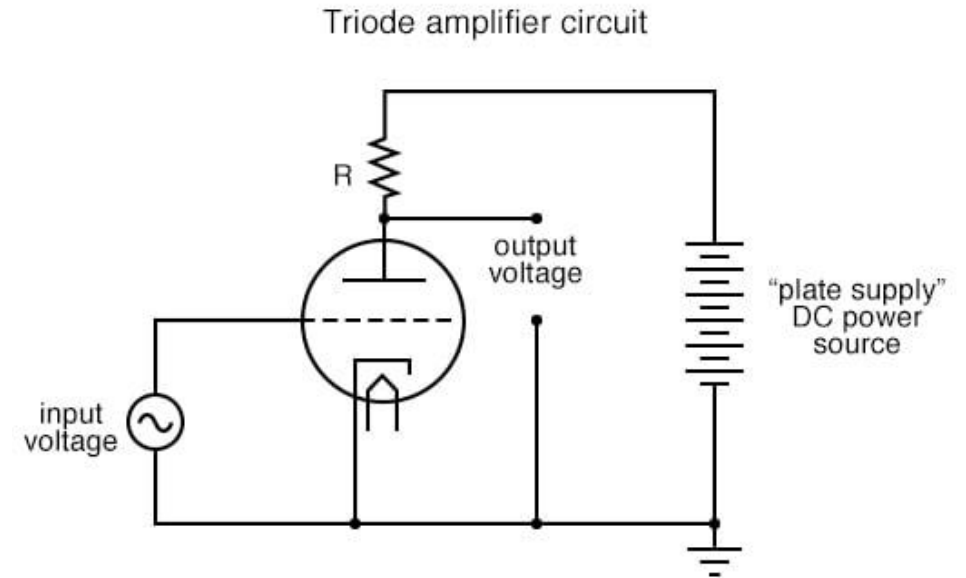

# WHY SPECIAL MICROWAVE TUBES ARE NECESSARY?

1. Conventional electronic Device tubes cannot be used for frequencies above 300MHz
  - a) Interelectrode capacitance
  - b) Lead Inductance effect
  - c) Transit time effect
  - d) Gain Bandwidth limitation
  
2. These effects leads to high RF losses in conventional tubes.

# PRINCIPLE OF OPERATION OF MICROWAVE TUBES

Efficient Microwave tubes usually operate on the theory of electron **velocity modulation** concept.

## Principle of Velocity Modulation

1. An electron traveling in the same direction as the electrostatic lines of force will decelerate by giving up energy to the field.
2. **The negatively charged body will repel the electron and cause it to decrease in velocity.**
3. **When the velocity is reduced, the energy level is also reduced.**
4. The energy lost by the electron is gained by the electrostatic field.

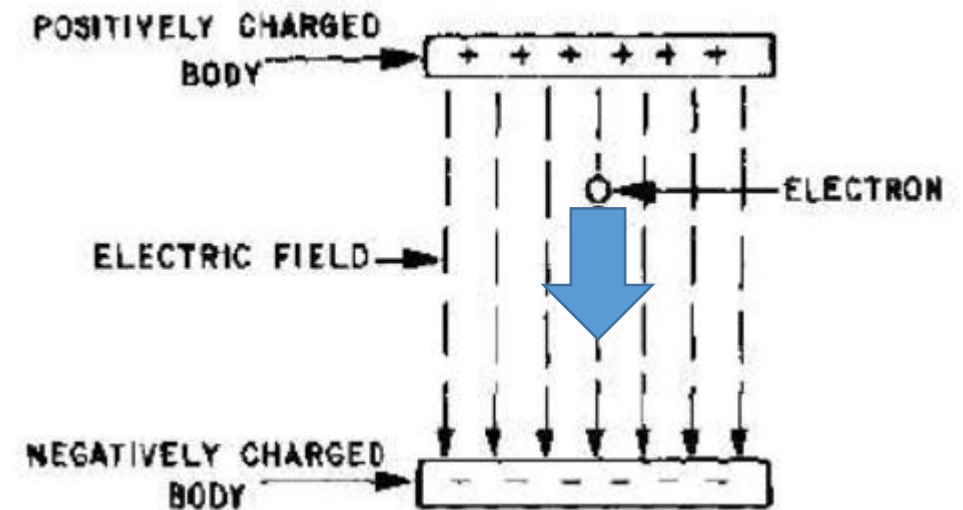

# TRAVELING WAVE TUBE (TWT)

Thursday, 06 February 2025

# DEFINITION

- A **traveling-wave tube (TWT)** or **traveling-wave tube amplifier (TWTA)** electronics to amplify radio frequency (RF) signals in the microwave range.

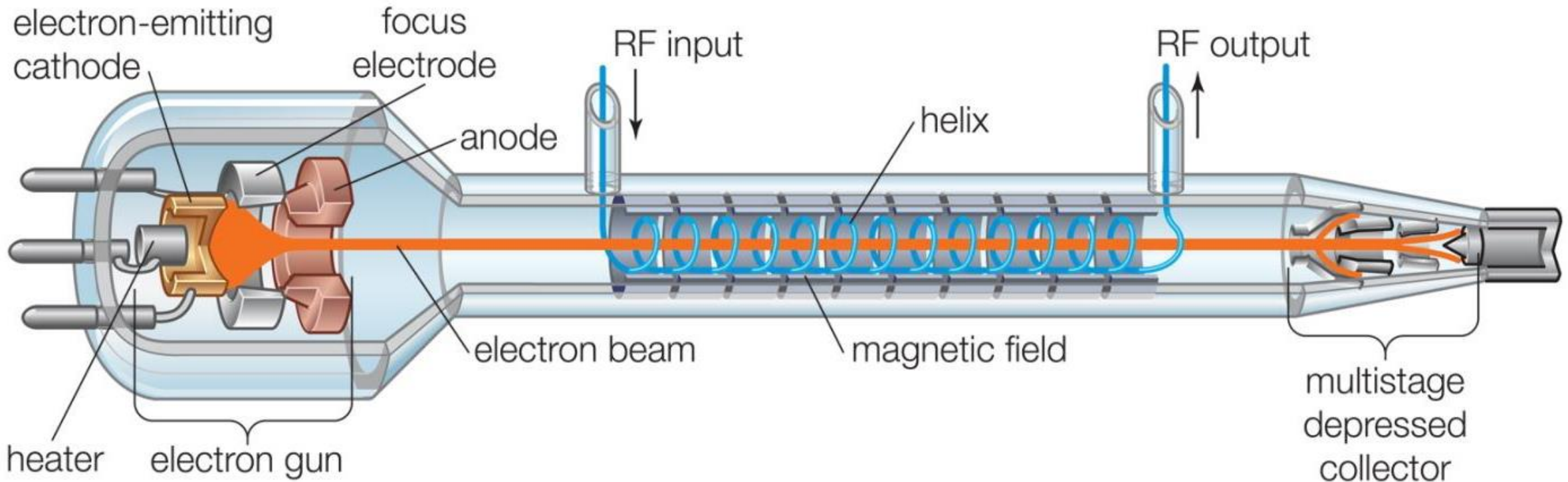

# TRAVELLING WAVE TUBE

- A **traveling-wave tube (TWT)** used to **amplify microwave signals to high power**, usually in an electronic assembly known as a **traveling-wave tube amplifier (TWTA)**.
- The bandwidth of a broadband **TWT can be as high as one octave**, although tuned (narrowband) versions exist.
- Operating frequencies range from **300 MHz to 50 GHz**.
- The **voltage gain of a TWT can be of the order of 70 decibels**

# TWT – THEORY (1)

- Electrons from a heated cathode are accelerated towards the anode, which is held at a high positive potential with respect to the cathode, and a proportion pass through a hole in the anode to produce the beam.

**Magnet**

Focuses the electrons towards the centre.

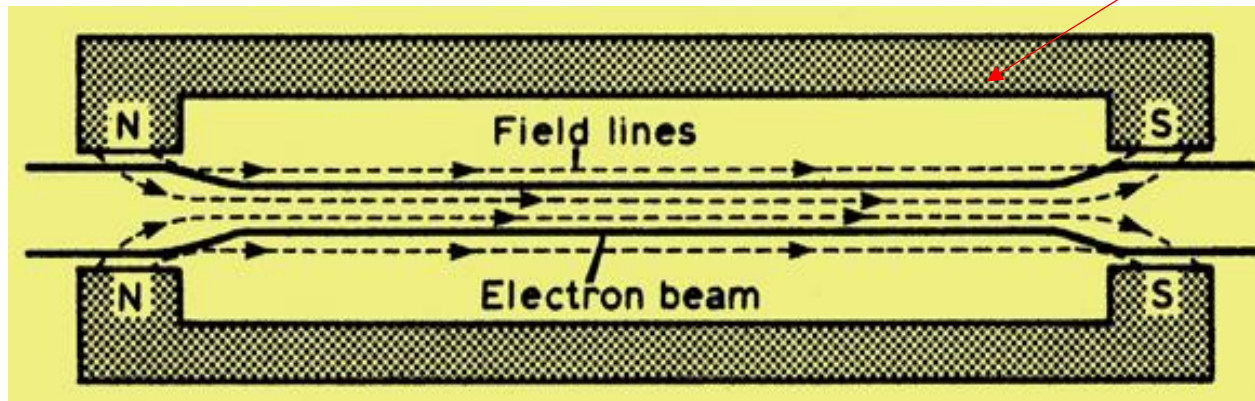

# TWT – THEORY (2)

- The velocity,  $v$ , of an electron beam in a TWT is given by:

$$v = \sqrt{\frac{2eV_a}{m}}$$

where  $V_a$  = accelerating anode voltage  
 $e$  = electron charge =  $1.6 \times 10^{-19} \text{C}$   
 $m$  = electron mass =  $9.1 \times 10^{-31} \text{kg}$

- An anode voltage of **5 kV** gives an electron velocity of  **$4.2 \times 10^7 \text{ m/s}$** . The signal would normally travel at  $c$ , the velocity of light ( **$3 \times 10^8 \text{ m/s}$** ), which is much faster than any 'reasonable' electron beam.
- If the signal can be **slowed down to the same velocity as the electron beam**, it is possible to obtain amplification of the signal by virtue of its interaction with the beam.

# TWT – THEORY (3)

1. Slowing is usually achieved using the helix electrode, which is simply a spiral of wire around the electron beam.
2. Without the helix, the signal would travel at a velocity  $c$ . With the helix, the axial signal velocity is approximately  $\frac{cp}{2\pi a}$  where  $a$ ,  $p$  are as shown on the left.
3. By proper selection of  $a$  and  $p$ , the signal can be slowed.

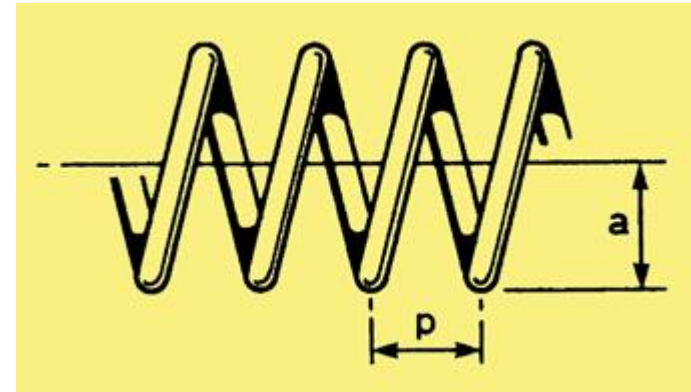

# TWT – THEORY (4)

4. The condition for equal slow-wave and electron-beam velocities is therefore approximately:

$$\frac{cp}{2\pi a} = \sqrt{\frac{2eVa.}{m}}$$

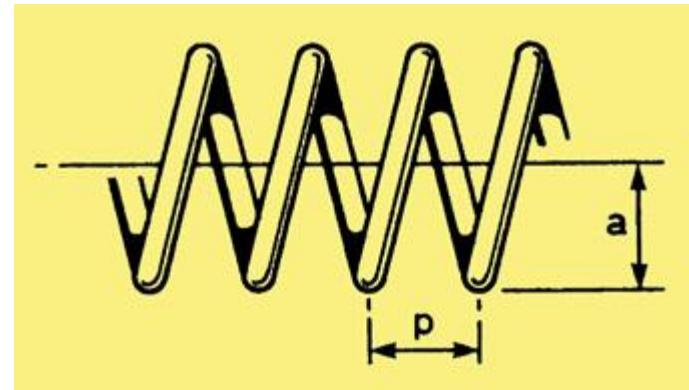

# TWT AMPLIFICATION

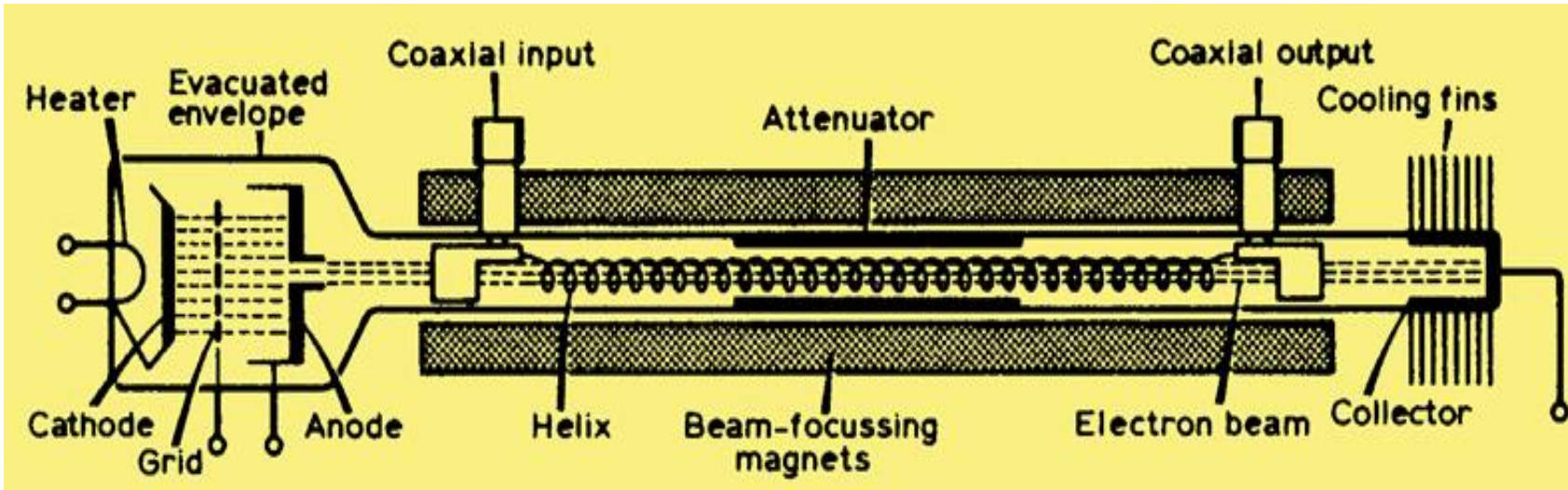

1. The interaction between the electron beam and the slow wave takes the form of **'velocity modulation' of the beam** (i.e some electrons are accelerated and some retarded) forming electron bunches within the beam.
2. The beam current becomes modulated by the RF signal, and the bunches react with the RF fields associated with the slow wave travelling down the helix, **resulting in a net transfer of energy from the beam to the signal, and consequent amplification.**

# TYPICAL POWER SUPPLY OF A TWT

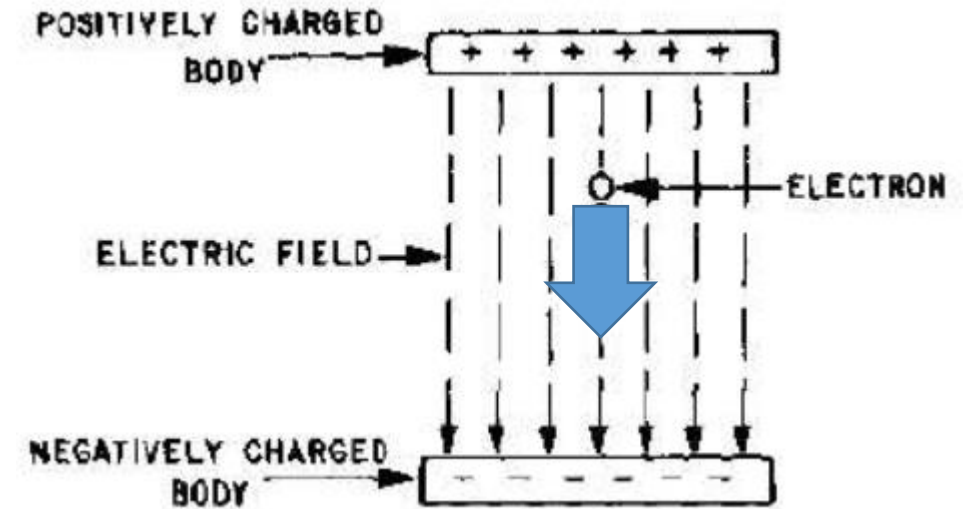
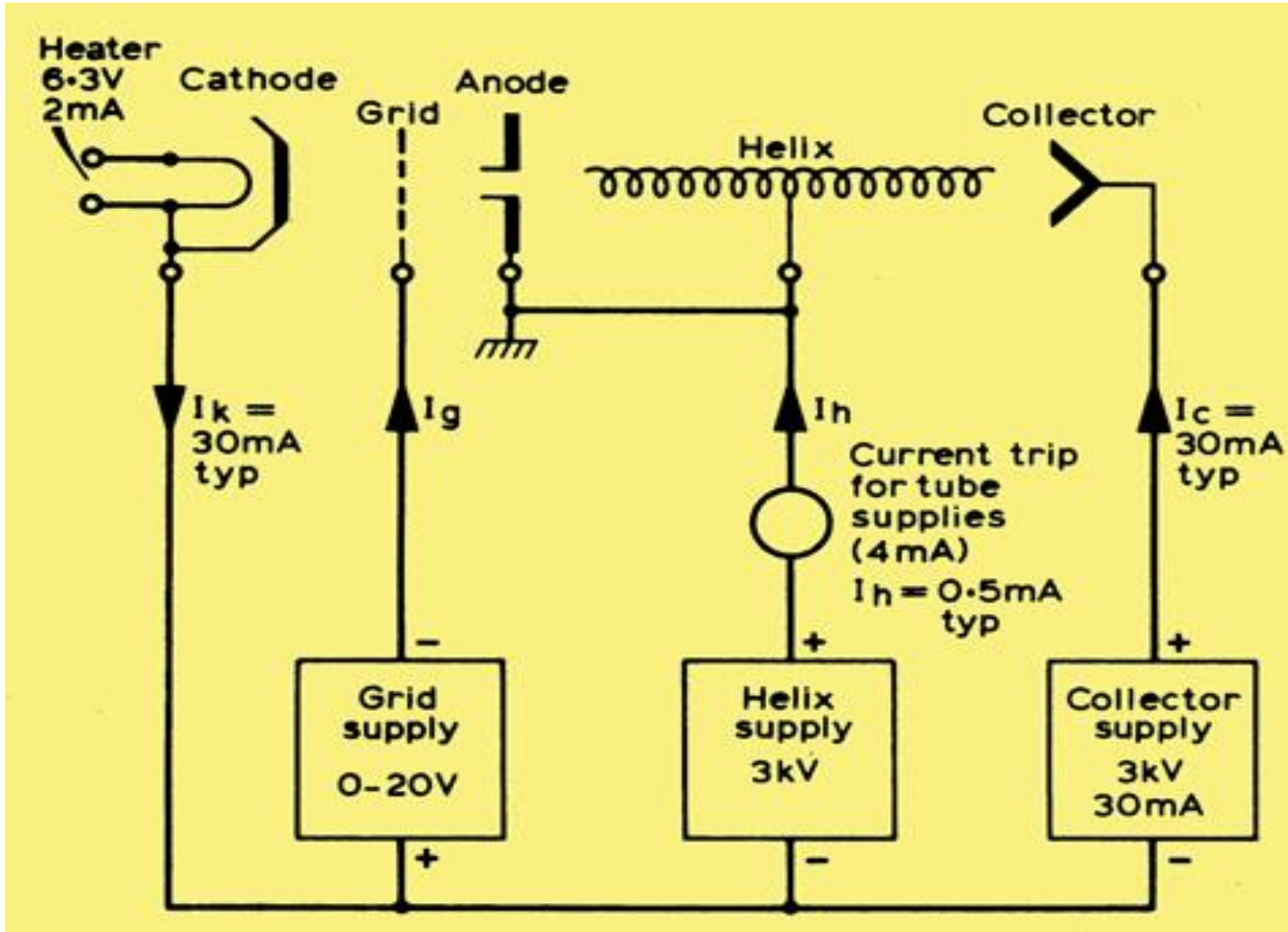

# FOCUSING MAGNETS (1)

1. The accelerated electron beam tends to diverge while moving through the Slow Wave Structure (SWS) due to space charge forces.
2. Large divergence of the electron beam leads to heating of the SWS which can lead to the destruction of the structure.
3. To combat divergence, an axial magnetic field is applied, forcing the electrons to travel the length of the tube without interception.

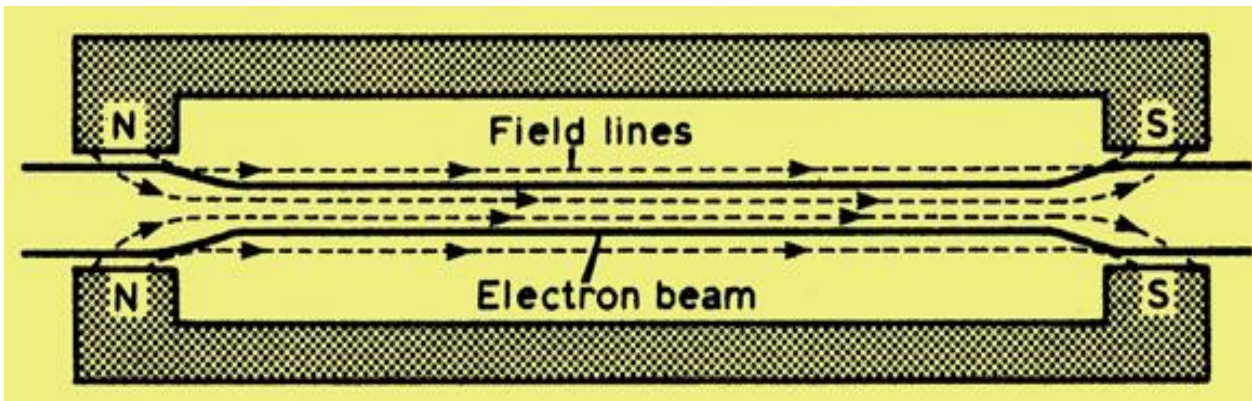
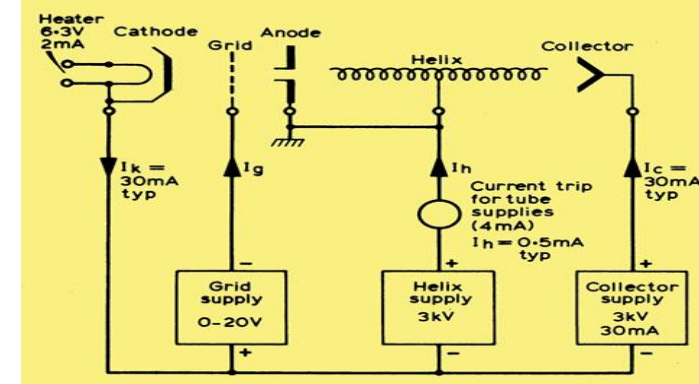

# FOCUSING MAGNETS (2)

1. To achieve good focusing by this method requires a very large magnetic field, **which can mean a bulky, heavy magnet.**
2. The arrangement usually employed is called **periodic permanent magnet (PPM) focussing**, in which a number of **toroidal permanent magnets of alternating polarity** is arranged along the tube.
3. Such arrangement reduces enormously the required **weight of magnet (under ideal conditions by a factor  $1/N^2$** ; where **N** is the number of magnets used).

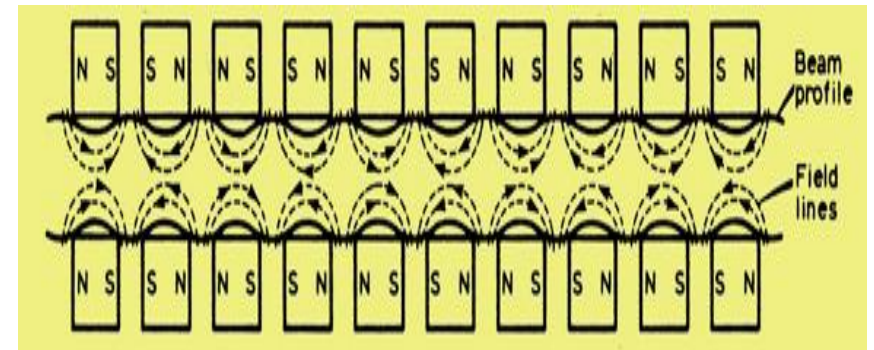
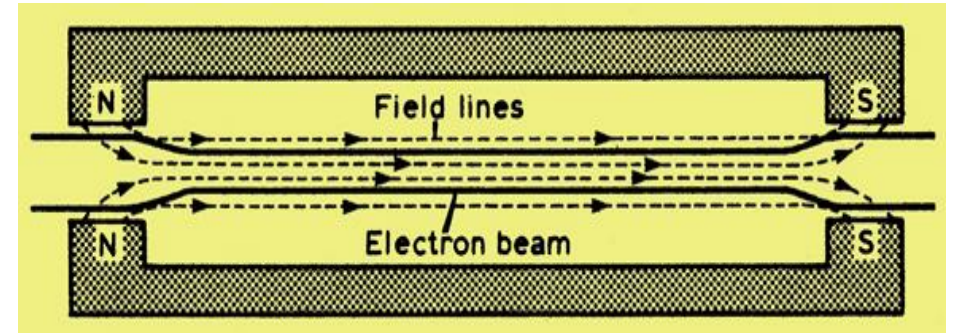

# BACKWARD WAVE OSCILLATORS (BWO)

EEEN 566 – MICROWAVE ENGINEERING

Thursday, 06 February 2025

# WHAT IS A BACKWARD WAVE OSCILLATOR?

1. A **backward wave oscillator (BWO)** is a vacuum tube device that **generates microwaves by propagating a traveling wave backwards against an electron beam**, essentially meaning the energy flow is opposite to the direction of the electron motion.
2. **BWO** is also known as a carcinotron or backward wave tube.
3. **BWO** can produce frequencies up to the terahertz range depending on its design.

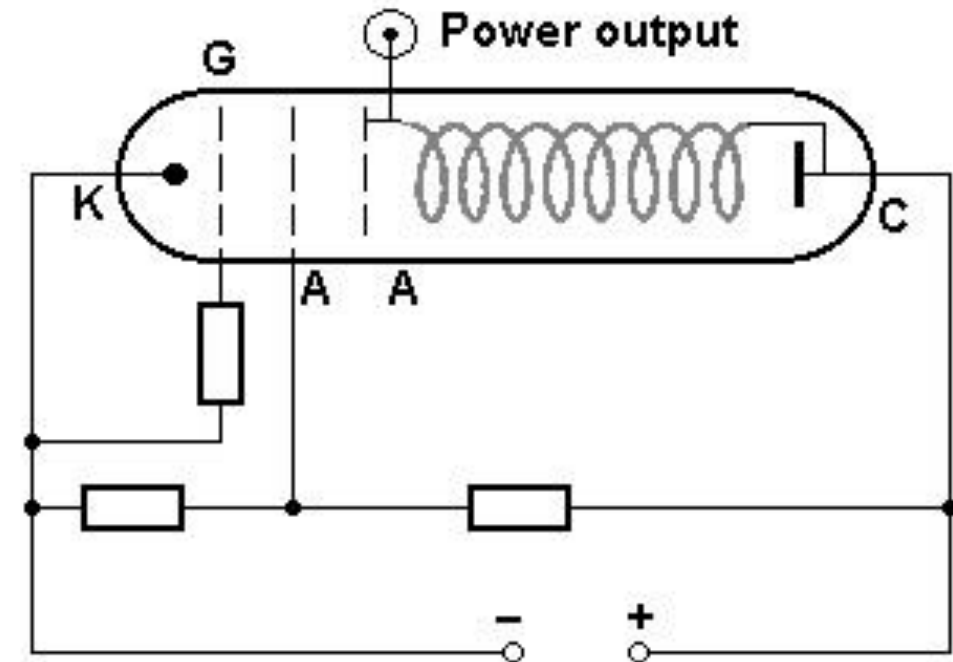

# PRINCIPLE OF OPERATION OF A BWO

1. An electron gun generates an electron beam that is interacting with a slow-wave structure (helix).
2. It sustains the oscillations by propagating a traveling wave backwards against the beam.
3. The generated electromagnetic wave power has its group velocity directed oppositely to the direction of motion of the electrons.
4. The output power is coupled out near the cathode (electron gun).

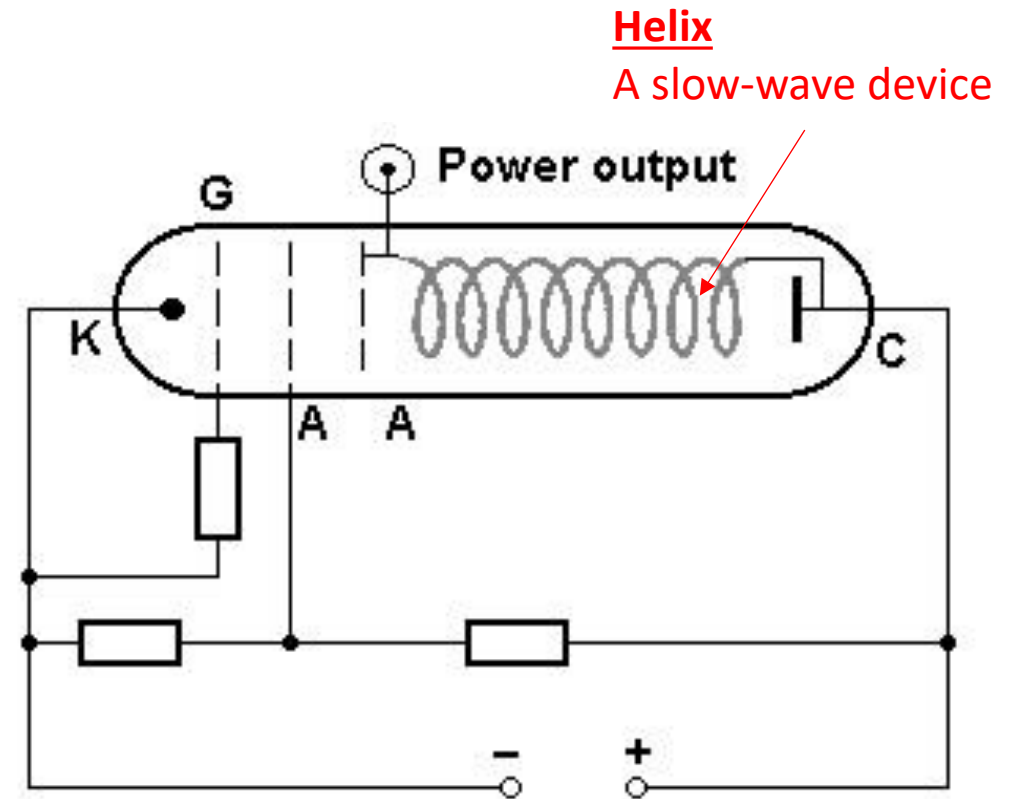

# O-TYPE BWO

1. **O-type backward wave oscillator**, uses an electron beam longitudinally focused by a magnetic field, and a slow-wave circuit interacting with the beam.
2. O-type BWO is a voltage tunable oscillator, whose voltage tuning rate is directly related to the propagation characteristics of the circuit.
3. The oscillation starts at a frequency where the wave propagating on the circuit is synchronous with the slow space charge wave of the beam.

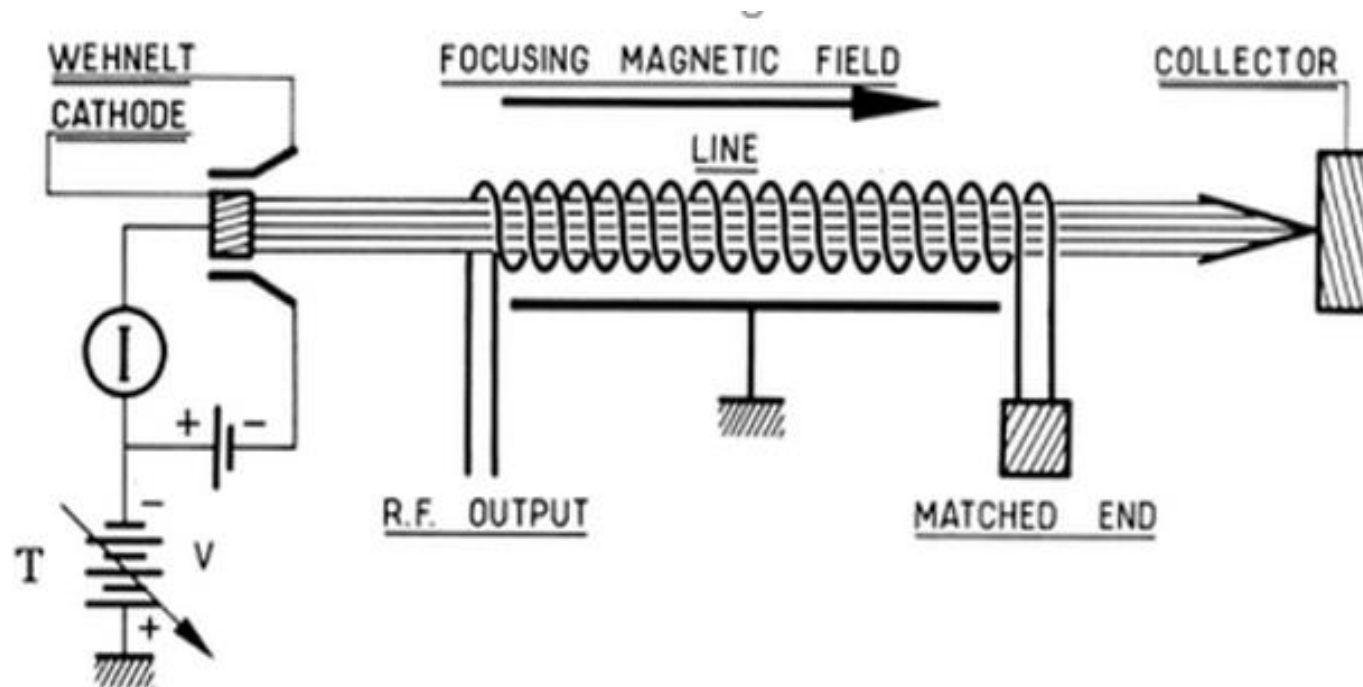

# O-TYPE BWO

## Electron Gun

produces a narrow, collimated electron beam that has a precise kinetic energy

## Focusing Magnetic field

Produced by one large permanent magnet or an assembly of small magnets

## Collector

Collects the electron beam at the end of the tube.

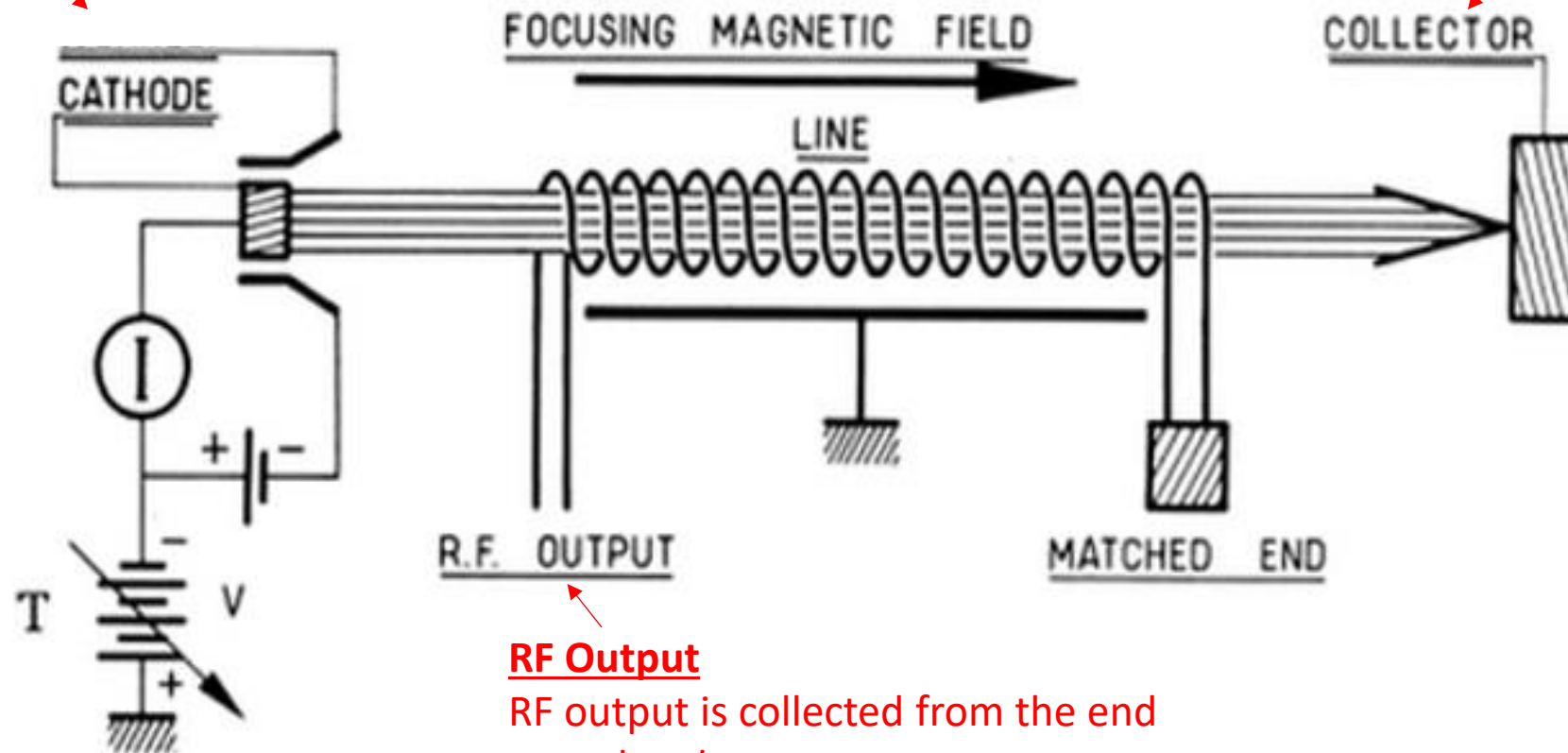

## RF Output

RF output is collected from the end near the electron gun

# M-TYPE BACKWARD WAVE OSCILLATOR (1)

- **M-type backward wave oscillator**, uses crossed static electric field  $E$  and magnetic field  $B$ , similar to the magnetron, for focusing an electron sheet beam drifting perpendicularly to  $E$  and  $B$ , along a slow-wave circuit, with a velocity  $E/B$ .
- Strong interaction occurs when the phase velocity of one space harmonic of the wave is equal to the electron velocity.

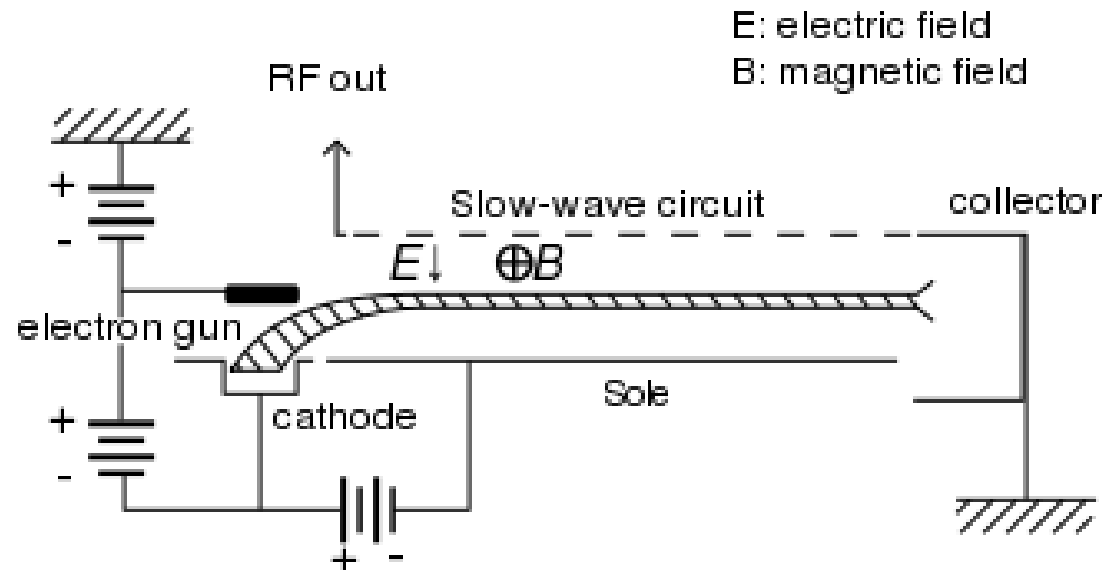

**Electron Gun**

produces a narrow, collimated electron beam that has a precise kinetic energy

**Electric fields**

Both  $E_z$  and  $E_y$  components of the RF field are involved in the interaction ( $E_y$  parallel to the static E field).

**Collector**

Collects the electron beam at the end of the tube.

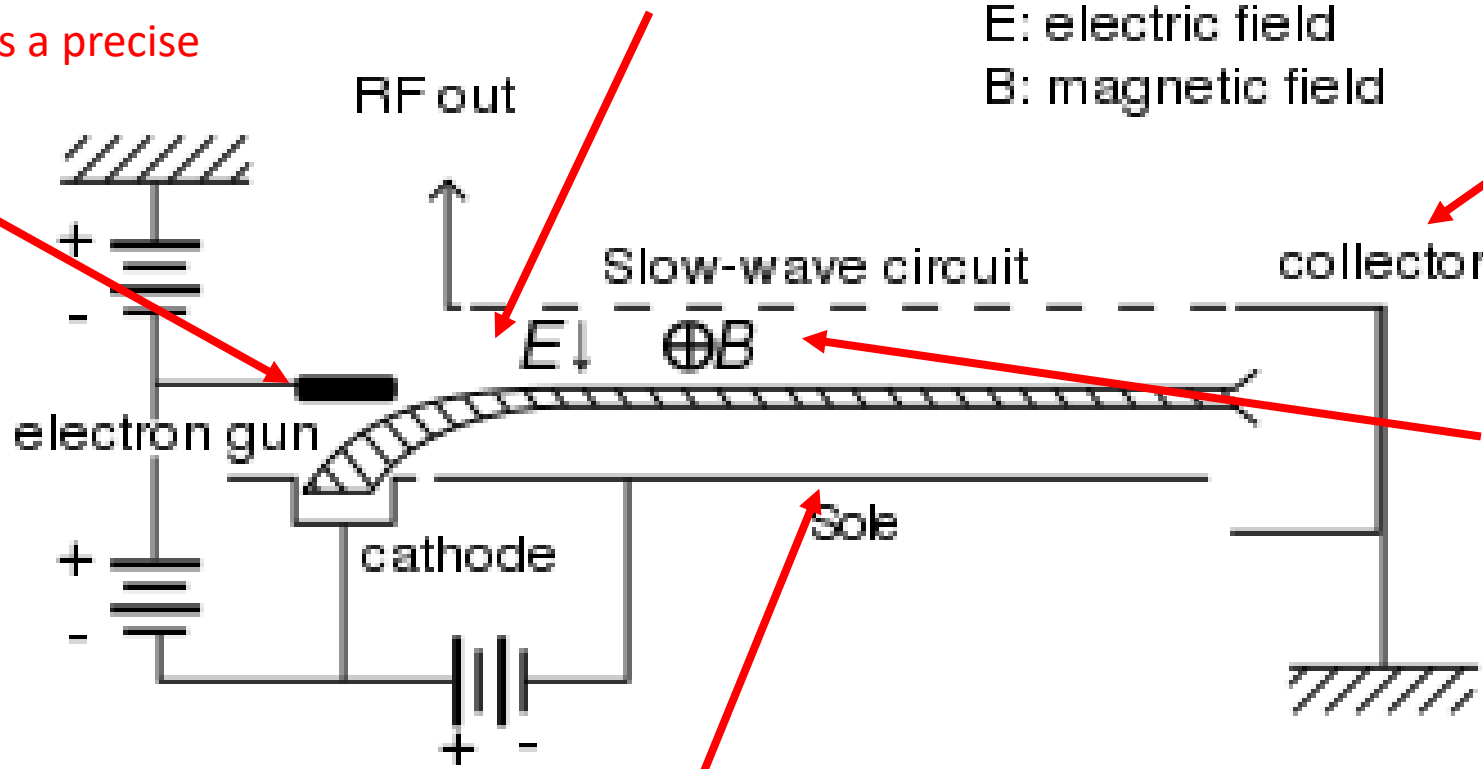

Electrons which are in a decelerating  $E_z$  electric field of the slow-wave, lose the potential energy they have in the static electric field E and reach the circuit.

**Sole**

Sole voltage is more negative than the cathode, in order to avoid collecting those electrons having gained energy while interacting with the slow-wave space harmonic.

# M-TYPE BACKWARD WAVE OSCILLATOR (2)

- M-type BWO with periodic delay line.

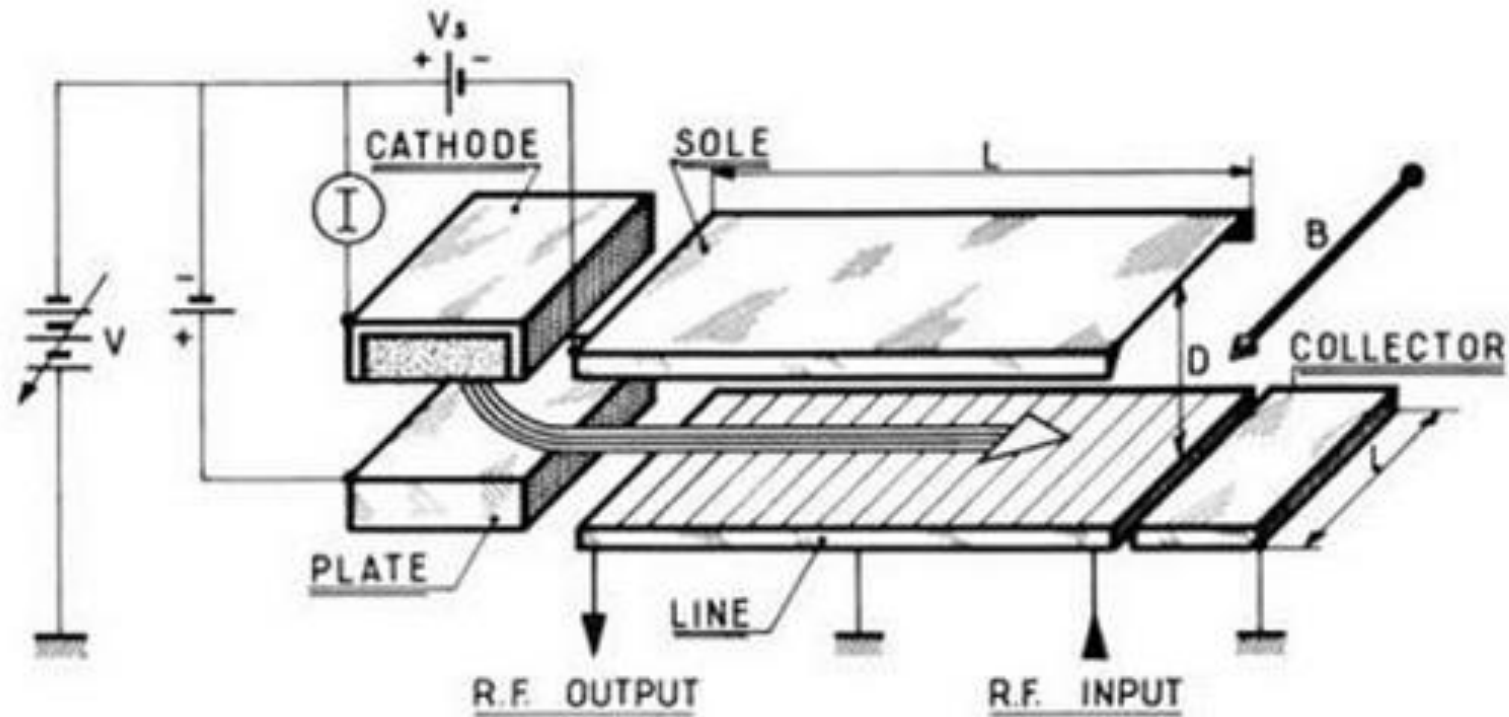

# COMPARING TWT WITH BWO

The difference between BWO and TWT are:

1. TWT is an amplifier while BWO is an oscillator
2. In Backward Wave Oscillator electron beam and electro-magnetic wave propagate in the opposite directions.
3. In BWO RF power is extracted at the output port located near the electron gun.

# APPLICATIONS OF BACKWARD WAVE OSCILLATOR

Due to their ability to produce high-power microwaves, BWOs are used in applications

1. Radar systems
2. High-frequency spectroscopy
3. Terahertz imaging
4. Plasma diagnostics
5. Source for high-frequency modulation studies

# KLYSTRONS

EEEN 566– MICROWAVE ENGINEERING

Thursday, February 6, 2025

# DEFINITION KLYSTRON

1. A klystron is a specialized linear-beam vacuum tube used as an amplifier/oscillator for high radio frequencies, from UHF up into the microwave range.
2. Klystron was invented in 1937 by American electrical engineers Russell and Sigurd Varian.
3. **Low-power klystrons** are used as oscillators in terrestrial microwave relay communications links.
4. **High-power klystrons** are used in UHF television transmitters, satellite communication, and radar transmitters.

# TYPES OF KLYSTRONS

There are two basic configurations of klystron tubes, i.e

1. **Reflex Klystron** in which the electron beam was reflected back along its path by a high potential electrode and functions as an oscillator.
2. **Multi-cavity klystron** which use more than two cavities and functions as an amplifier.

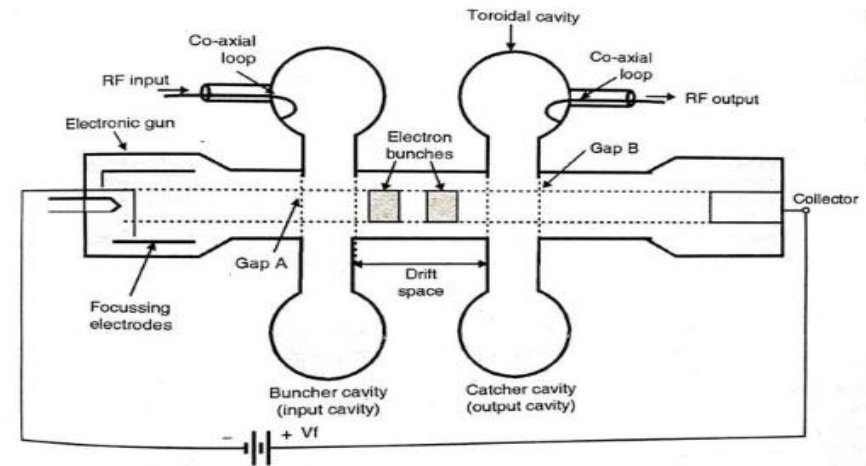
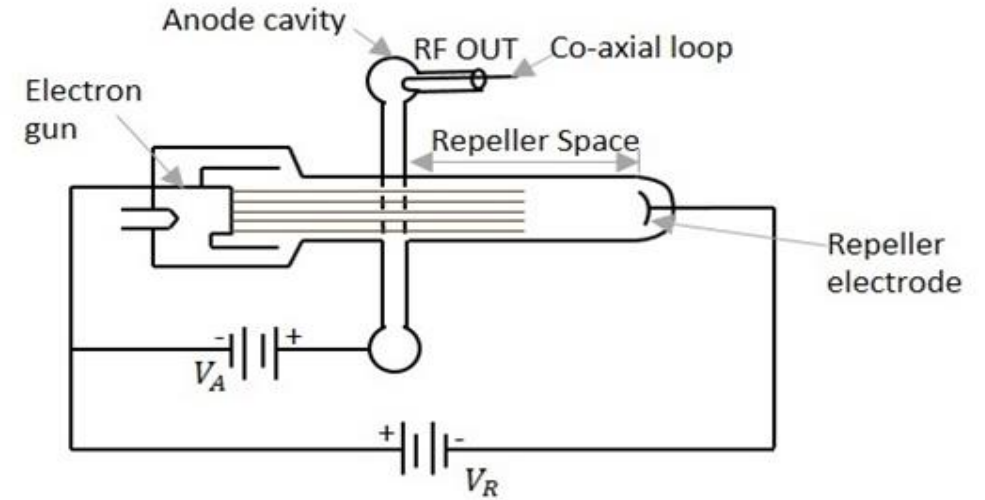

# REFLEX KLYSTRON

## Electron Gun

The cathode and the accelerating grid inject high speed electrons into the cavity

## Repeller

Deflects the electrons to the resonant cavity

## Voltage Adjuster

The voltage on the reflector must be adjusted so that the bunching is at a maximum as the electron beam re-enters the resonant cavity to ensure maximum transfer of energy

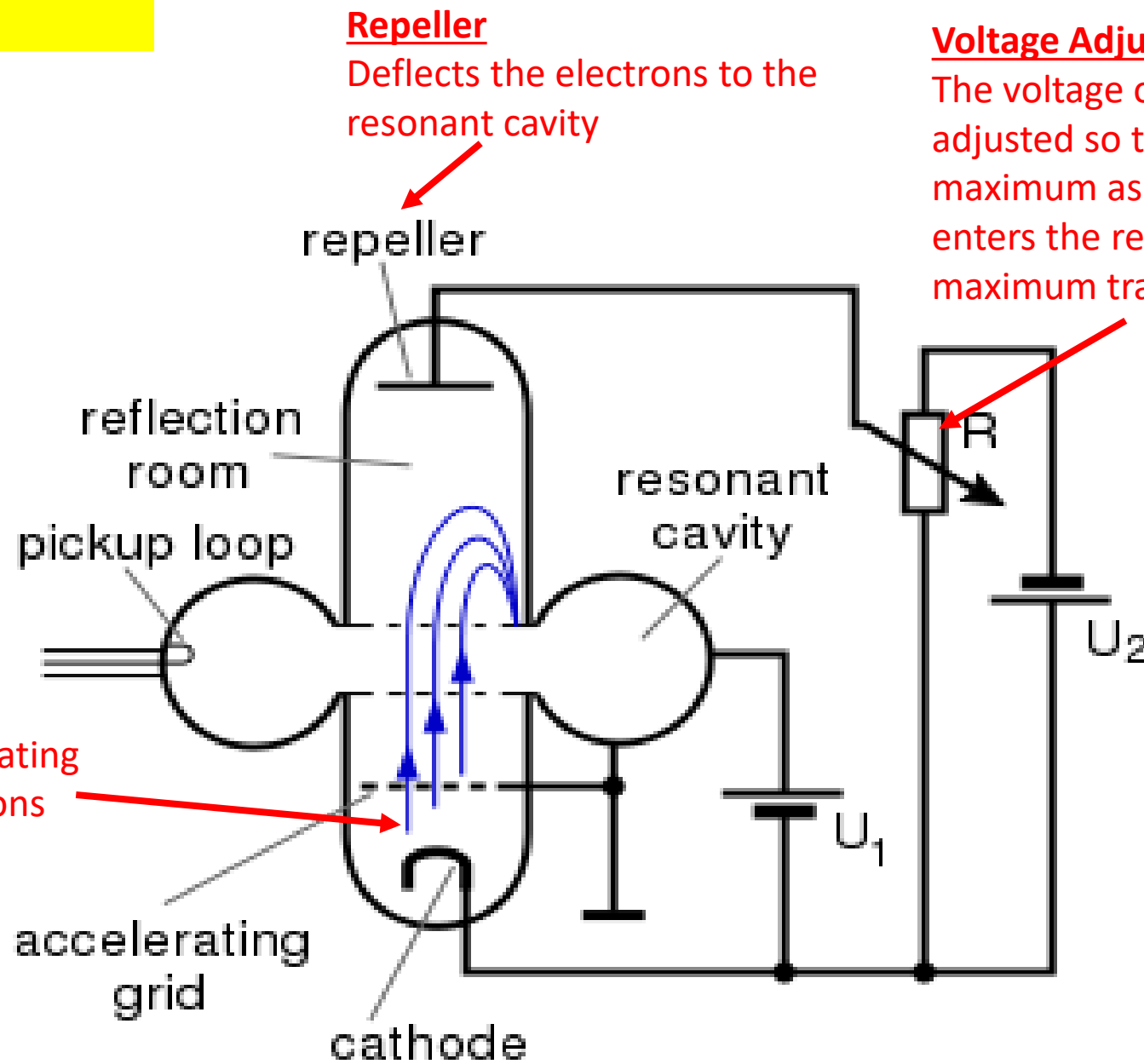

# TWO-CAVITY KLYSTRON

## Electron Gun

The cathode and the accelerating grid inject high speed electrons into the cavity

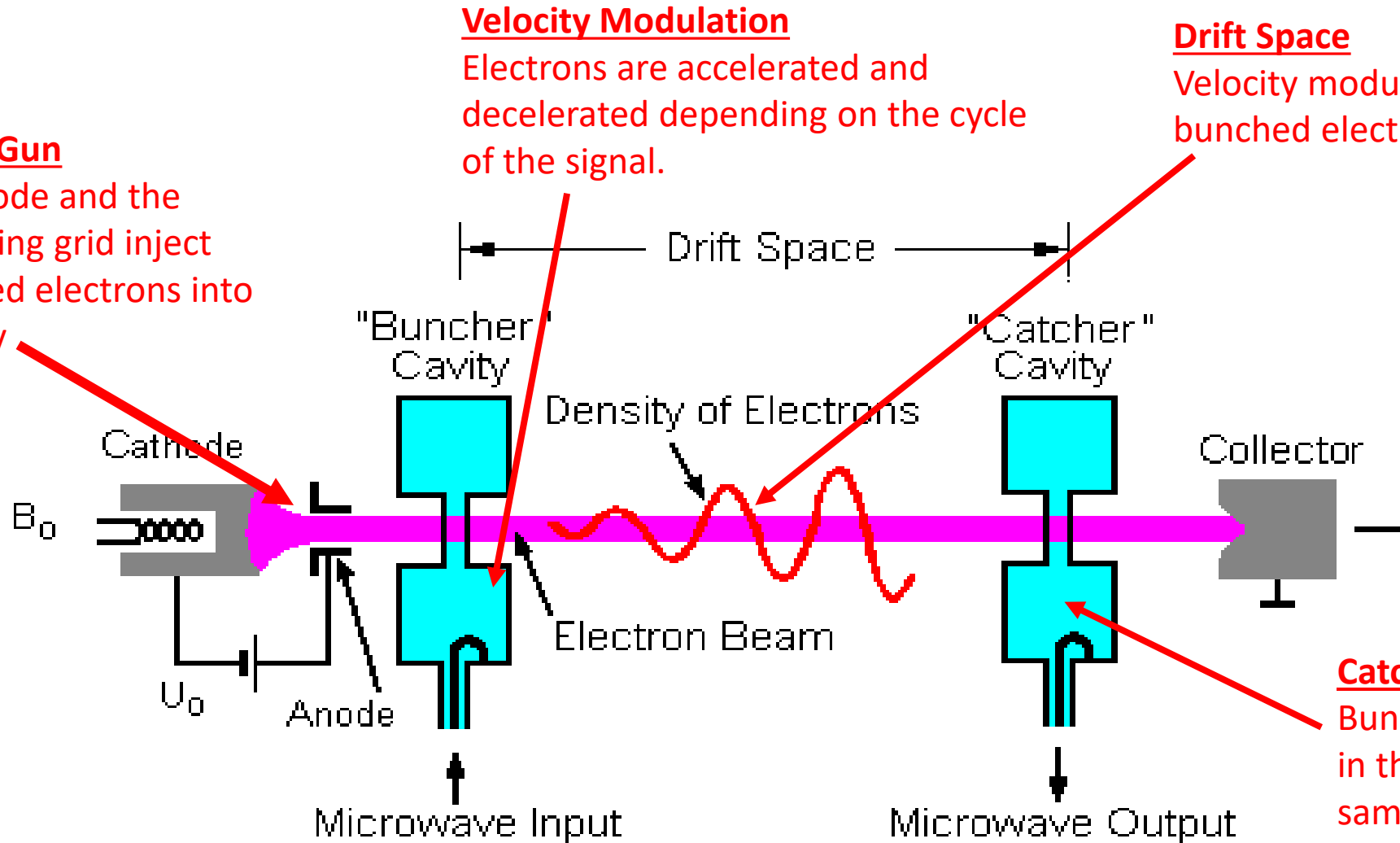

## Velocity Modulation

Electrons are accelerated and decelerated depending on the cycle of the signal.

## Drift Space

Velocity modulated or bunched electrons

## Catcher

Bunches excite standing waves in the cavity, which has the same resonant frequency as the buncher cavity leading to absorption